

FURUNO

NAVpilot

Model NAVpilot-300 / 711C



NAVpilot-300
with Gesture Controller



NAVpilot-711C



www.furuno.com

NAVpilot-300

NAVpilot-711C

Control Unit FAP-3011

0.25 kg 0.53 lb

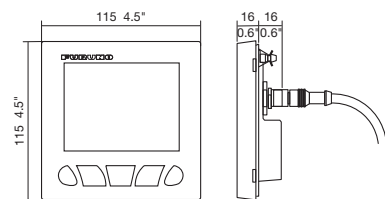

Gesture Controller GC-001

0.12 kg 0.26 lb

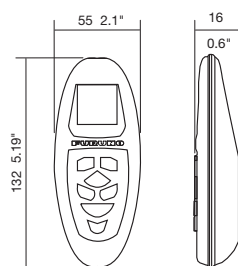

Processor Unit FAP-3012

1.5 kg 3.3 lb

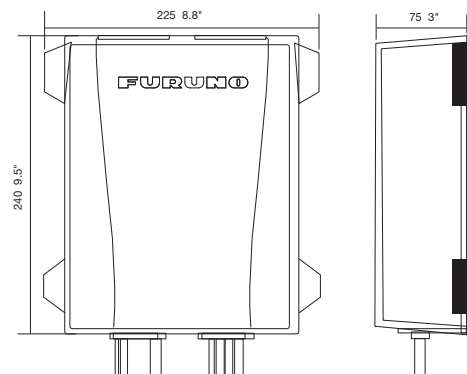

Control Unit FAP-7011C

0.25 kg 0.53 lb

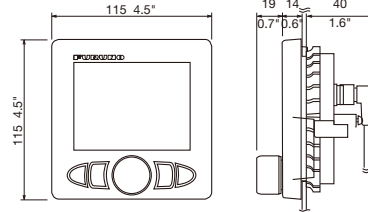

Cut-out for flush mount
(Wall thickness less than 10 mm)

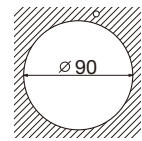

Cut-out for flush mount
(Wall thickness 10 to 20 mm)

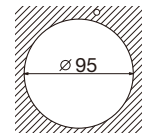

Processor Unit FAP-7002

0.25 kg 0.53 lb

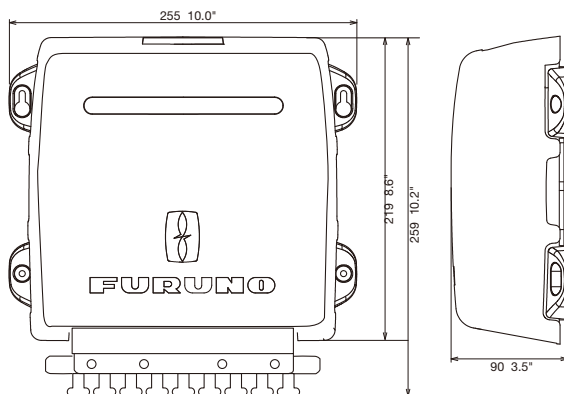

INTERCONNECTION DIAGRAM

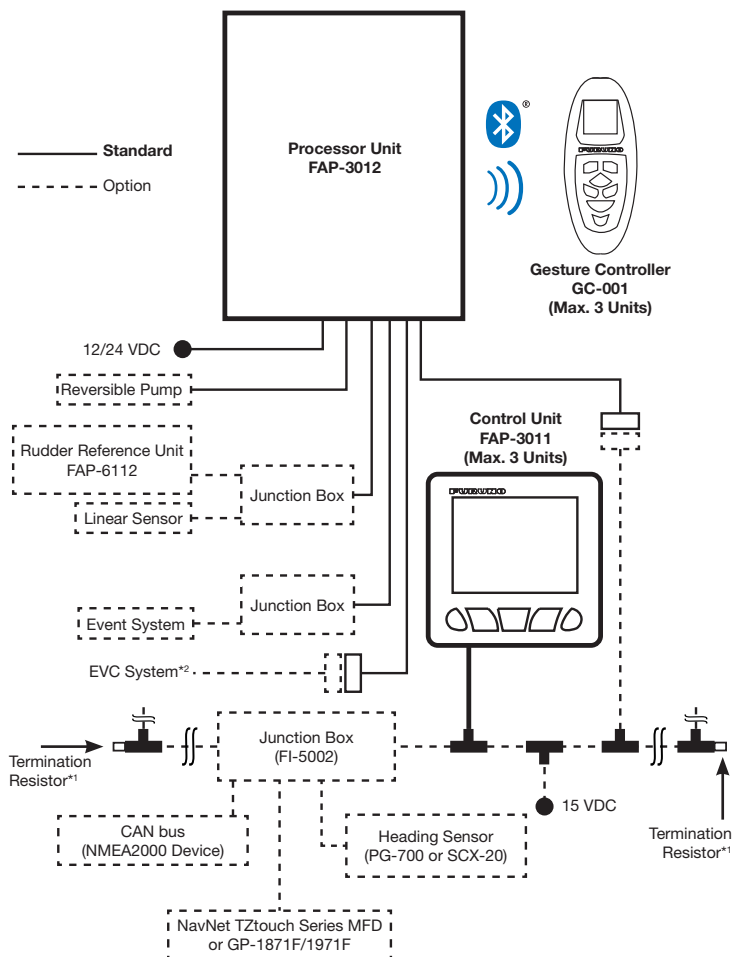

*1: Termination resistors must be installed at both ends of the backbone.
*2: YANMAR VC10, SEASTAR SOLUTIONS OPTIMUS

INTERCONNECTION DIAGRAM

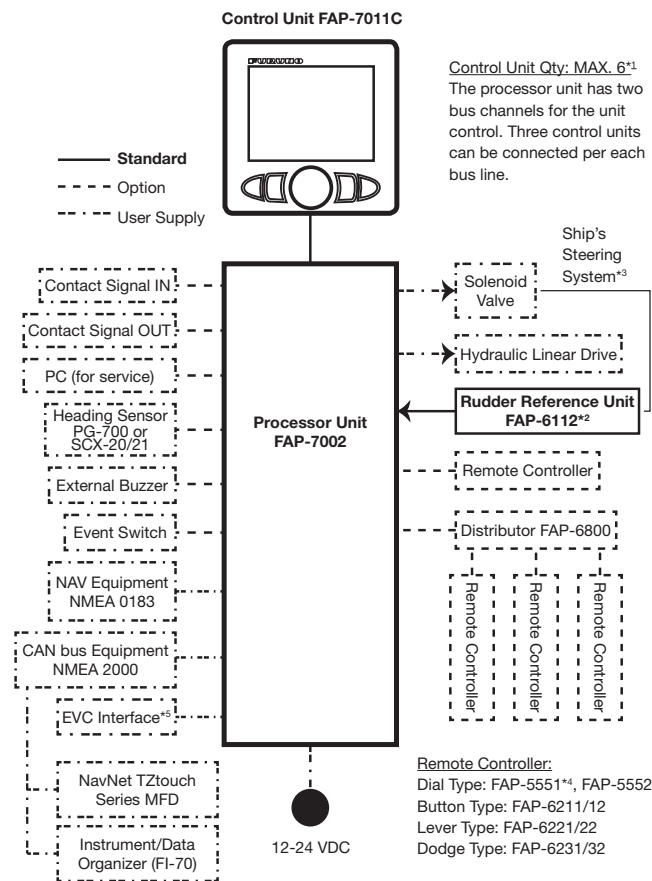

Control Unit Qty: MAX. 6*1
The processor unit has two bus channels for the unit control. Three control units can be connected per each bus line.

Remote Controller:
Dial Type: FAP-5551**
Button Type: FAP-6211/12
Lever Type: FAP-6221/22
Dodge Type: FAP-6231/32

*1: Attach the terminator (type: BD-07AFFM-LR7001) to the port not used on the last control unit in the series.
*2: Not required for Fantum Feedback™.
*3: Not required for an EVC system equipped vessel.
*4: Connect one Dial-type Remote Controller FAP-5551 to one Distributor FAP-6800.
*5: YANMAR VC10, SEASTAR SOLUTIONS OPTIMUS

NAVpilot



GC-001



NAVpilot-300



NAVpilot-711C



NAVpilot remarkable self-learning, adaptive software is developed by collaborative works between FURUNO and FLSI.



KEY FEATURES:

- ▶ Self-Learning and adaptive software; each time the boat goes to sea, the software learns the sea conditions and calculates the best adjustment for smooth steering
- ▶ Fantum Feedback™ offers simplified installation while delivering enhanced steering control - no need for physical rudder feedback unit
- ▶ Yanmar and Seastar VCS compatible
- ▶ Easy installation and smart network-based system configuration
- ▶ Waterproof Processing Unit (IP55) and Control Unit (IP56, IP65/67 for GC001)
- ▶ Selectable “Economy” and “Precision” Navigation Modes combine adaptive technology, providing fuel and power savings of 2.5% or more*
- ▶ “Precision” provides tighter course keeping, within 0.01 NM of the set course
- ▶ Perfect for inboard or outboard power boats and sail boats (NAVpilot-711C only)
- ▶ Autopilot control available from NavNet TZtouchXL/TZtouchE/TZtouch3/TZtouch2/TZtouch/TZMAP/GP-1871F/1971F
- ▶ NEW! FishHunter™ Drive delivers new control features for boaters utilizing select Suzuki outboard models (NavPilot-300 only)

Remote Navigation In The Palm of Your Hands (NAVpilot-300 only)

The Gesture Controller is a revolutionary and unique way to steer your boat remotely. By using Bluetooth signals, it is possible to control the Autopilot from anywhere on the boat within 10 meters. Just push and hold the button, point to the desired heading, and release the button to let the Autopilot redirect the boat!

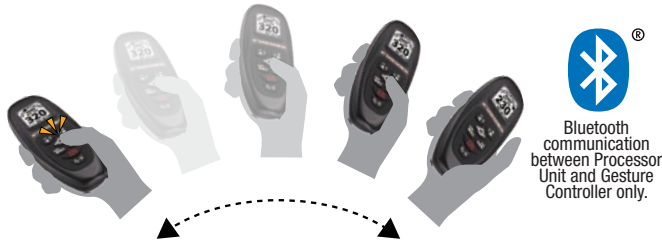

Autopilot Control from NavNet TZtouch Series and TZMAP

Furuno's NAVpilot Series are designed to match the NavNet TZtouch Series, TZMAP, GPS Chart Plotter GP-1871F/GP-1971F, and other Furuno navigation equipment. The Plug and Play CAN bus interface allows for easy installation and exceptional interfacing.

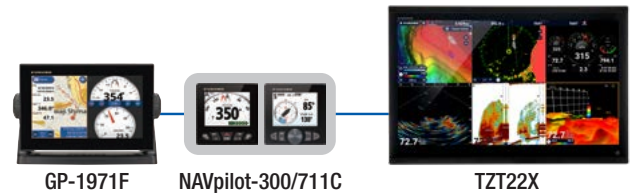

SABIKI™ Mode for NAVpilot-300 and NAVpilot-711C

SABIKI™ mode lets the Autopilot take control while you are drifting astern so you can focus on fishing instead of steering. When moving astern at a slow pace, SABIKI™ mode is uniquely tailored for SABIKI fishing, jigging and bottom fishing. In order to maintain heading it is not sufficient to just reverse the engine and move astern. The steering has to be constantly adjusted in order to hold your heading. With SABIKI™ mode turned on, the direction can be kept just by adjusting the throttle. SABIKI fishing requires a bit of technique and whether you just started or have considerable experience, SABIKI™ mode will help you catch the bait fish needed for the big catch.

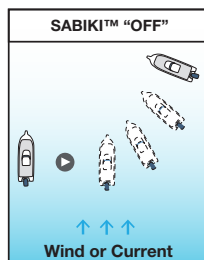
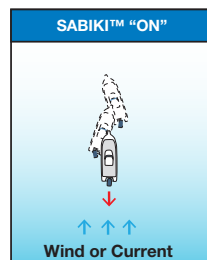

SABIKI™ mode is only user selectable if the current speed is below 5 knots. Once SABIKI™ mode is selected, the course can be set with the course knob and the arrow keys.

Compatible with EVC Engines

The NAVpilot-300/711C have the capability to work with Yanmar 8LV engine systems* and the Seastar Optimus360 Joystick system*.

* Required the optional IFNMEA2K2 to connect with NAVpilot-300/711C.

FishHunter™ Drive for Suzuki Outboards

Speed Control	The boat will maintain a constant speed, adjusting engine RPM as needed to account for changes in wind and tide.
Route Smoothing™	Decreases the speed of turns at waypoints while navigating an active route. Reducing speed when executing a turn helps keep the vessel on course.
Point Lock™	Allows the vessel to easily maintain a fixed position by controlling the rudder and throttle, countering the effects of wind and tide, which are constantly working to move the boat. An invaluable tool for anglers to maintain a fixed position while fishing a wreck or reef, and for boaters who occasionally must wait for a bridge to open so they can pass.
Auto Stop On Arrival	The NavPilot-300 automatically stops the vessel at the destination waypoint. When combined with the Point Lock™ feature, Auto Stop On Arrival allows the vessel to maintain a fixed position at the destination waypoint.
SABIKI Lock™	Expands upon the NavPilot-300's SABIKI™ functionality by controlling both the rudder and throttle to maintain position, freeing the angler to focus 100% on jigging and other vertical fishing.

Display Options for Day and Night

Several types of graphic displays are available, allowing you to customize the data to suit your own preferences with either digital or analog graphics. The NAVpilot-300 and NAVpilot-711C feature a color day/night graphic display, giving you better sunlight viewability during the day, while not affecting your night vision when the sun goes down.

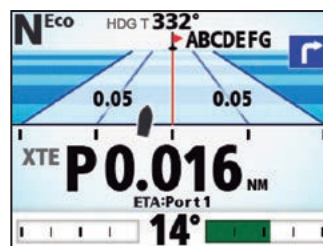

Highway Mode Day



Highway Mode Night

NAVpilot Offers Self-Learning and Adaptive Software

From the first dockside setup through the last voyage you made, NAVpilot continues to learn your vessel's steering characteristics. This allows dynamic adjustments to the boat's steering for vessel speed, trim, draft, tide and wind effects, weather, etc. These characteristics are stored in the processor's memory where they are continuously optimized to make the NAVpilot more versatile.

Auto

Maintains the desired heading, but the vessel may drift off course due to the effects of tide and wind.

Advanced Auto

Maintains the desired heading while compensating for the effects of tide and wind.

SABIKI™

Maintains the desired heading astern while compensating for the effects of tide and wind. Speed is limited to 5 knots.

Navigation

Steers the vessel towards the current waypoint while compensating for the effects of tide and wind.

Navigation

When connected to a GPS navigator, NAVpilot steers the vessel to follow a series of waypoints in succession. Upon arriving at each waypoint or destination, audible or visual alerts are activated.

Wind*

Maintains the desired heading toward true or apparent wind direction while compensating for the effects of tide and wind.
*Sailing craft only with proper wind data input

FishHunter™

FH

Square | **Zigzag** | **Orbit** | **Figure 8** | **Spiral**

The NAVpilot will activate the FishHunter™ to perform various maneuvers around the target at a user-selected distance. The feature can also be used for Man Overboard (MOB).

MODEL		NAVpilot-300	NAVpilot-711C
CONTROL UNIT			
Screen Size/Type		4.1" TFT color LCD	
Effective Display Area		82.56 (W) x 61.92 (H) mm	
Screen Resolution		320 x 240 dots (QVGA)	
Screen Brightness		700 cd/m ² typical	
Screen Contrast		8 steps	
PROCESSOR UNIT			
Steering Mode	STBY, Auto, Dodge, NFU (Non-follow up), Turn, SABIKI™, FishHunter™, Advanced Auto*, Navigation* *External data required	STBY, Auto, Dodge, Turn, Remote, SABIKI™, Advanced Auto*, Navigation*, Wind*, FishHunter™* *External data required	
Weather Mode	--	Auto, Manual-Calm/Moderate/Rough	
Rudder Gain		Auto/1-20 (Manual)	
Counter Rudder		Auto/0-20 (Manual)	
Trim Gain		Auto/1-20 (Manual)	
Trim Adjustment	-5° (port) to +5° (stbd)	--	
Change Course Speed	1-20 deg/s	1-30 deg/s	
Rudder Angle Settings	--	10-45 deg	
Alarm	Heading deviation, Watch	Heading deviation, Cross-track error*, Ship's Speed*, Depth*, Water temperature*, Wind*, Watch, Log Trip* *External data required	
Motor Drive	10 A continuous, 20 A for 5 seconds	25 A continuous, 50 A for 5 seconds	
GESTURE CONTROLLER (NAVpilot-300 only)			
Screen Type/Resolution	1.28" Monochrome TFT LCD, 128 x 128 pixels	--	
Communication Distance	10 m (depending on environmental conditions)	--	
INTERFACE			
Ports	NMEA2000 x1, CAN bus x1 (DBW control), Contact signal x3, Bluetooth (Gesture Controller)	NMEA0183 x2, CAN bus x1, Contact signal x2	
Input	NMEA0183	--	AAM, APB, BOD, BWC, BWR, DBT, DPT, GGA, GLL, GNS, HDG, HDM, HDT, MTW, MWV, ROT, RMB, RMC, THS, TLL, VHW, VTG, VWR, VWT, XTE, ZDA
	NMEA2000	059392/904, 060160/416/928, 061184, 065240, 126208/464/720/992/996, 127237/250/258, 128259, 129025/026/029/283/284/285/538, 130577/818/821/827/841	059392/904, 060928, 061184, 126208/720/992/996, 127250/251/258/488/489, 128259/267, 129025/026/029/033/283/284/285, 130306/310/311/312/313/314/577818/821/827/880
Output	NMEA0183	--	DBT, DPT, GGA, GLL, GNS, HDG, HDM, HDT, MTW, MWV, RMB, RMC, ROT, RSA, VHW, VTG, VWR, VWT, ZDA
	NMEA2000	059392/904, 060928, 126208/464/720/993/996/998, 127237/245, 130816/821/822/823/827/841	059392/904, 060928, 061184, 126208/464/720/992/996, 127237/245/250/251/258, 128259/267, 129025/026/029/033/283/284/285, 130306/310/311/312/822/823/827
ENVIRONMENT			
Temperature		-15°C to +55°C	
Waterproofing	Processor Unit: IP55 Control Unit: IP56 Gesture Controller: IP65/67	Processor Unit: IP20 Control Unit: IP56	
POWER SUPPLY			
Processor Unit	12-24 VDC 0.22 A max. (LEN: 2)	12-24 VDC: 4.0-2.0 A (control unit: 6 sets), excluding pump	
Control Unit	15 VDC 0.29 A max.(LEN: 6)	--	
Gesture Controller	VDC, Dry cell battery (AAA x2)	--	
EQUIPMENT LIST			
Standard	Control Unit (FAP-3011), Processor Unit (FAP-3012), Gesture Controller (GC-001), Installation Materials, Accessories, and Spare Parts	Control Unit (FAP-7011C), Processor Unit (FAP-7002), Rudder Reference Unit (FAP-6112), Integrated Heading Sensor (PG-700), Installation Materials and Spare Parts	
Options	Control Unit (FAP-3011), Gesture Controller (GC-001), Bracket-mount Kits, Cables, Connectors, Junction Box, Pump Unit, Rudder Reference Unit	Control Units, Flush Mount Kits, Bracket-mount Kits, Cradle, Rudder Reference Units (FAP6112-200), Remote Controllers, Cables, Connectors, Junction Box, Pump Unit	
FishHunter™ Drive - Refer to online flyer for more information			
Engine	Suzuki Outboards	DF140BG/115BG, DF200AP/175AP/DF150AP, DF300AP/250AP, DF350AMD/DF300BMD, DF350A/325A*/300B *Not Available in US	
	Supported Quantity	Maximum 4 units	
Autopilot	NAVpilot-300		
Display Device	NavNet TZtouchXL series – TZT10X/13X/16X/22X/24X/BBX NavNet TZtouchE series – TZT9E/TZT13E NavNet TZtouch3 series – TZT9F/12F/16F/19F NavNet TZtouch2 series – TZTL12F/L15F/2BB SMD series – SMD7/9 and SMD12/16	TZMAP – TZMAP9E/TZMAP13E GP-1871F/1971F For active route output to SUZUKI engines, autopilot mode display, etc.	
Navigation Data	Heading, position, and vessel speed sensors for autopilot control (MFD internal GPS does not meet all requirements, SCX-20 recommended)	E-2604LB Catalog No. CA000002842	

