

# **FURUNO**

## **OPERATOR'S MANUAL**

*MARINE DISPLAY*

Model **MU-152**

---

(Product Name: MONITOR UNIT)



# IMPORTANT NOTICES

---

## General

- This manual has been authored with simplified grammar, to meet the needs of international users.
- The operator of this equipment must read and follow the instructions in this manual. Wrong operation or maintenance can void the warranty or cause injury.
- Do not copy any part of this manual without written permission from FURUNO.
- If this manual is lost or worn, contact your dealer about replacement.
- The contents of this manual and the equipment specifications can change without notice.
- The example screens (or illustrations) shown in this manual can be different from the screens you see on your display. The screens you see depend on your system configuration and equipment settings.
- Save this manual for future reference.
- Any modification of the equipment (including software) by persons not authorized by FURUNO will void the warranty.
- The following concern acts as our importer in Europe, as defined in DECISION No 768/2008/EC.
  - Name: FURUNO EUROPE B.V.
  - Address: Siriusstraat 86, 5015 BT, Tilburg, The Netherlands
- The following concern acts as our importer in UK, as defined in SI 2016/1025 as amended SI 2019/470.
  - Name: FURUNO (UK) LTD.
  - Address: West Building Penner Road Havant Hampshire PO9 1QY, U.K.
- All brand, product names, trademarks, registered trademarks, and service marks belong to their respective holders.

## How to discard this product

Discard this product according to local regulations for the disposal of industrial waste. For disposal in the USA, see the homepage of the Electronics Industries Alliance (<http://www.eiae.org/>) for the correct method of disposal.

## How to discard a used battery

Some FURUNO products have a battery(ies). To see if your product has a battery, see the chapter on Maintenance. Follow the instructions below if a battery is used. Tape the + and - terminals of battery before disposal to prevent fire, heat generation caused by short circuit.

### In the European Union

The crossed-out trash can symbol indicates that all types of batteries must not be discarded in standard trash, or at a trash site. Take the used batteries to a battery collection site according to your national legislation and the Batteries Directive 2006/66/EU.

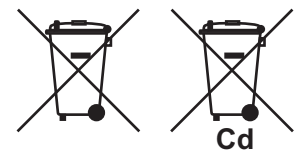

### In the USA

The Mobius loop symbol (three chasing arrows) indicates that Ni-Cd and lead-acid rechargeable batteries must be recycled. Take the used batteries to a battery collection site according to local laws.

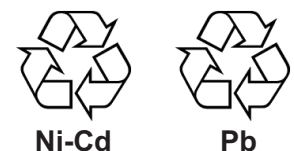

### In the other countries

There are no international standards for the battery recycle symbol. The number of symbols can increase when the other countries make their own recycle symbols in the future.



# SAFETY INSTRUCTIONS

Read these safety instructions before you operate the equipment.



## WARNING

Indicates a condition that can cause death or serious injury if not avoided.



## CAUTION

Indicates a condition that can cause minor or moderate injury if not avoided.



Warning, Caution



Prohibitive Action



Mandatory Action

### Safety Instructions for the Operator



## WARNING



**Immediately turn off the power at the switchboard if water leaks into the equipment or something is dropped into the equipment.**

Continued use of the equipment can cause fire or electrical shock. Contact your dealer.



**Immediately turn off the power at the switchboard if the equipment is emitting smoke or fire.**

Continued use of the equipment can cause fire or electrical shock. Contact your dealer.



**Turn off the power immediately if you feel the equipment is behaving abnormally.**

Turn off the power at the switchboard if the equipment becomes abnormally warm or is emitting odd noises. Contact your dealer.



## WARNING



**Do not disassemble or modify the equipment.**

Fire, electrical shock or serious injury can result.



**Use the proper fuse.**

Use of a wrong fuse can cause fire or damage to the equipment.



## CAUTION



**Do not connect/disconnect the signal cable while the power is turned on.**

The unit may be damaged.



**Handle the display carefully.**

Injury can result if the display breaks.

***Safety Instructions for the Installer*****⚠ WARNING**

**!** Turn off the power at the switchboard before beginning the installation.

Fire or electrical shock can result if the power is left on.



**Do not install the equipment where it may get wet from rain or water splash.**

Water in the equipment can result in fire, electrical shock or damage to the equipment.

**⚠ CAUTION**

**!** Observe the following compass safe distances to prevent interference to a magnetic compass:

	Standard compass	Steering compass
MU-152	0.65 m	0.40 m

**!** When lifting the monitor unit, hold it together with the hard cover.

Grasping by the hard cover alone may allow the monitor unit to fall, resulting in possible bodily injury or damage to the equipment.

**!** This equipment is intended to enhance safe operation of the vessel. Install it on the bridge or captain's quarters where access is limited to few personnel (captain, navigator).

**About the TFT LCD**

- The TFT LCD is constructed using the latest LCD techniques, and displays 99.99% of its pixels. The remaining 0.01% of the pixels may drop out or blink, however this is not an indication of malfunction.
- The MU-152 is non-bonding monitor unit, so the dew condensation may occur depending on the ambient temperature.

# TABLE OF CONTENTS

---

<b>FOREWORD</b> .....	<b>v</b>
<b>SYSTEM CONFIGURATION</b> .....	<b>vi</b>
<b>EQUIPMENT LISTS</b> .....	<b>vii</b>
<b>1. MOUNTING, WIRING</b> .....	<b>1</b>
1.1 Preparation .....	1
1.2 Flush Mounting, Fixed at Rear (Standard) .....	3
1.3 Flush Mounting, Fixed at Front (Option) .....	5
1.4 Desktop Mounting (Option) .....	6
1.5 Flush Mounting, Fixed at Rear, with Hood (Option) .....	8
1.6 Desktop Mounting, with Hood (Option) .....	10
1.7 Replacing the MU-151C with the MU-152 .....	10
1.8 Wiring .....	11
<b>2. ADJUSTMENTS</b> .....	<b>12</b>
2.1 RGB/DVI Setting .....	12
2.2 Video Composite Signal Setting .....	14
2.3 The Menu Window Setting .....	15
2.3.1 How to adjust the menu window .....	15
2.3.2 How to change the signal name .....	16
<b>3. OPERATION</b> .....	<b>17</b>
3.1 Controls .....	17
3.2 How to Turn the Power On/Off .....	18
3.2.1 Turn the power on/off .....	18
3.2.2 Lock the key operation .....	18
3.3 How to Adjust the Display Brilliance .....	19
3.4 How to Select the Source for Main Picture .....	19
3.5 How to Display the PIP Window .....	19
3.6 SYSTEM Menu .....	20
3.6.1 How to set the auto dimmer .....	20
3.6.2 How to adjust the brilliance from the external equipment .....	21
3.6.3 How to clear the memory .....	21
<b>4. MAINTENANCE, TROUBLESHOOTING</b> .....	<b>22</b>
4.1 Maintenance .....	22
4.2 Troubleshooting .....	23
<b>APPX. 1 ABBREVIATIONS</b> .....	<b>AP-1</b>
<b>SPECIFICATIONS</b> .....	<b>SP-1</b>
<b>INSTALLATION MATERIALS</b> .....	<b>A-1</b>
<b>OUTLINE DRAWINGS</b> .....	<b>D-1</b>
<b>INTERCONNECTION DIAGRAM</b> .....	<b>S-1</b>

# FOREWORD

---

## A Word to the Owner of the MU-152

FURUNO Electric Company thanks you for purchasing the MU-152 15" Marine Display. We are confident you will discover why the FURUNO name has become synonymous with quality and reliability.

Since 1948, FURUNO Electric Company has enjoyed an enviable reputation for quality and reliability throughout the world. This dedication to excellence is furthered by our extensive global network of agents and dealers.

Your equipment is designed and constructed to meet the rigorous demands of the marine environment. However, no machine can perform its intended function unless properly installed and maintained. Please carefully read and follow the operation, installation and maintenance procedures set forth in this manual.

We would appreciate feedback from you, the end-user, about whether we are achieving our purposes.

Thank you for considering and purchasing FURUNO.

## Features

The main features of the MU-152 are as shown below.

- Selectable display format (RGB × 1 line, Digital × 2 lines, Composite × 3 lines).
- Main or remote display for various equipment. For the connectable equipment, see "Connectable equipment (Landscape orientation only)" on page vi.
- All glass, narrow frame design
- Display resolution of 1024 × 768 (XGA)
- Brightness of 400 cd/m<sup>2</sup>
- Automatic brilliance adjustment with the light sensor.
- Picture-in-picture function
- Power on/off automatically via DVI signal.

## Program

Program Name	Version	Date of Change
APR PROGRAM	2651038-xx.xx	Jul. 2017

xx denotes minor modifications.

## CE/UKCA declaration

With regards to CE/UKCA declarations, please refer to our website ([www.furuno.com](http://www.furuno.com)), for further information about RoHS conformity declarations.

## Disclosure of Information about China RoHS

With regards to China RoHS information for our products, please refer to our website ([www.furuno.com](http://www.furuno.com)).

# SYSTEM CONFIGURATION

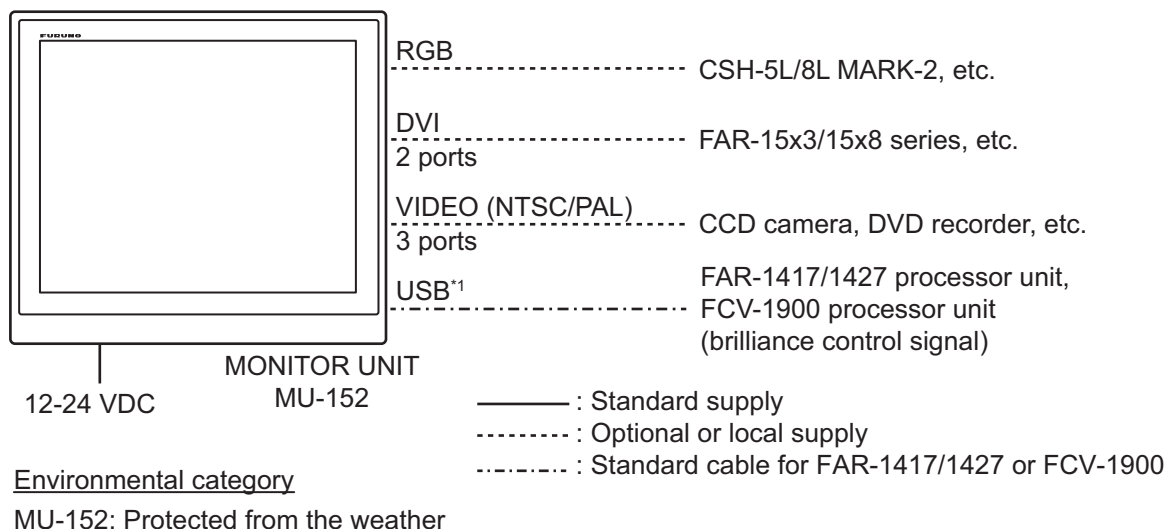

\*1: The USB port is for the brilliance control signal from the external equipment. You can not connect a PC or other device.

## Connectable equipment (Landscape orientation only)

Equipment	Resolution	Signal
CH-250/250S	VGA	Analog RGB, via IF-8000
CH-270	VGA	Analog RGB, via IF-8000
CH-300	VGA	Analog RGB, via IF-8000
CSH-5L/8L	XGA	Analog RGB
CSH-5L/8L MARK-2	XGA	Analog RGB
CH-500/600	XGA	DVI
FSV-35/35S	SXGA <sup>*3</sup>	DVI
FCV-30	XGA/SXGA <sup>*3</sup>	Analog RGB
FCV-2100	XGA/SXGA <sup>*3</sup>	DVI
FCV-2100-MARK-2	XGA/SXGA <sup>*3</sup>	DVI <sup>*4</sup>
FCV-1900	XGA/SXGA <sup>*3</sup>	DVI
CI-38/68/88	VGA	Analog RGB
FAR-15x3/15x8 series	XGA	DVI
FAR-1417/1427 <sup>*2</sup>	XGA/SXGA <sup>*3</sup>	DVI
GD-300 <sup>*2</sup>	XGA	DVI
GD-700 <sup>*2</sup>	XGA/SXGA <sup>*3</sup>	DVI

\*2: For Japan only

\*3: For SXGA input, a circle may be displayed as an ellipse because the aspect ratio differs. See "[DISP MODE]\*\*\*" on page 13. Also, it may be difficult to read small characters.

\*4: To connect to the FCV-2100-MARK-2, use the HDMI-DVI cable (option for the FCV-2100-MARK-2).

# EQUIPMENT LISTS

## Standard supply

Name	Type	Qty	Remarks
Monitor Unit	MU-152	1	
Installation Materials	CP26-02400	1 set	Contents of Installation Materials <ul style="list-style-type: none"> <li>• Flush Mount Fixture 15 (CP26-01303)</li> <li>• CP26-02401*</li> <li>• Cable Assembly (MJ-A3SPF0013B-035C)</li> </ul>
Accessories	FP26-00800	1 set	Contents of Accessories <ul style="list-style-type: none"> <li>• Hard Cover 15 (26-005-2111-1)</li> </ul>
Spare Parts	SP66-00503	1 set	Contents of Spare Parts <ul style="list-style-type: none"> <li>• Glass Tube Fuse (FGBO-A 125V 3A PBF) 3 pcs.</li> </ul>

\*: See the Installation materials at the back of this manual.

## Optional supply

Name	Type	Qty	Remarks
Cable Assembly	3COX-2P-6C 5M	1	Cable length: 5 m (15 pin D-sub connector at both ends)
	3COX-2P-6C 10M	1	Cable length: 10 m (15 pin D-sub connector at both ends)
	DVI-D/D S-LINK 5M	1	Cable length: 5 m (with DVI-D connector at both ends)
	DVI-D/D S-LINK 10M	1	Cable length: 10 m (with DVI-D connector at both ends)
Bracket Assembly (w/knobs)	OP26-35	1 set	
Hood Assembly	OP26-3	1 set	
Flush Mount Kit	OP26-36	1 set	
Accessories	FP26-00401	1	LCD Cleaning Cloth (19-028-3125-6)
Flush Mounting Template	C42-00903-B	1	For flush mounting, fixed at rear
Operator's Manual	OMJ-44970	1	Japanese version
Glass Fixing Kit	OP26-37	1 set	For flush mouting (fixed at rear)/desktop mounting
Glass Fixing Kit (front)	OP26-38	1 set	For flush mouting (fixed at front)

# 1. MOUNTING, WIRING

---

## 1.1 Preparation

### Mounting type

You can install the monitor unit as follows. See the outline drawings at the back of this manual for mounting dimensions.

- Flush mounting, fixed at rear (standard)
- Flush mounting, fixed at front (option)
- Desktop mounting (option)
- Flush mounting, fixed at rear, with hood (option)
- Desktop mounting, with hood (option)

**Note 1:** The face of the LCD monitor is made of glass. Handle it with care.

**Note 2:** For flush mounting, the mounting surface must be flat. Do not install the unit on an uneven surface. Also, take care that the monitor unit does not fall during the installation.

### Mounting location

When you select a mounting location, remember the following points:

- Make sure the mounting location is strong enough to support the weight of the unit. See the outline drawings at the back of this manual.
- Locate the unit away from direct sunlight. An LCD may black out or condensation may occur if the LCD is exposed to direct sunlight for a long time.
- Select a location where the display can be easily viewed and the controls can be easily operated.
- Leave enough space around the unit for service and maintenance. See the outline drawings at the back of this manual for minimum service clearance.
- Locate the unit away from areas subject to water splash and rain. This monitor unit is for indoor.
- Observe the compass safe distances (see page iii) to prevent interference to a magnetic compass.

**Note:** If the unit is installed with the screen tilted downwards, the appropriate glass fixing kit (see "Optional supply" on page vii) must be used.

### Included items

- Monitor Unit
- Flush Mount Fixture 15 (2 pcs.)
- Flush Mounting Sponge H15 (2 pcs.)
- Flush Mounting Sponge V15 (2 pcs.)
- Washer Head Screw (6 pcs.)
- Cable Tie (4 pcs.)
- Cable Assembly (1 pc.)
- Hard Cover 15 (1 pc.)
- Glass Tube Fuse (3 pcs.)
- Operator's Manual (1 pc.)
- Material Data Sheet (C-RoHS, 1 pc.)

### Required tools

The following tools should be prepared in advance for this installation.

- Electrical drill, Hole saw:  $\phi 18$  mm, for making the mounting holes
- Jig saw, File: For making the mounting holes
- Phillips-head screw driver: #2, for securing the flush mount fixtures
- Cable tie: For securing the cables

### How to remove/attach the hard cover

Before you install this monitor unit, remove the hard cover as follows.

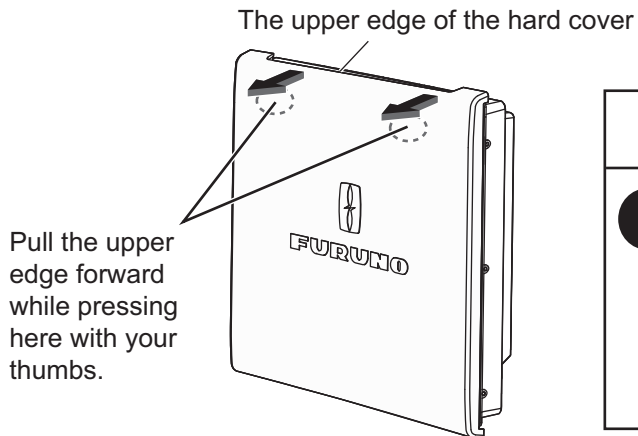

### **CAUTION**

**!** When lifting the monitor unit, hold it together with the hard cover.

Grasping by the hard cover alone may allow the monitor unit to fall, resulting in possible bodily injury or damage to the equipment.

*How to remove the hard cover*

To attach the hard cover, follow the illustration in the figure below.

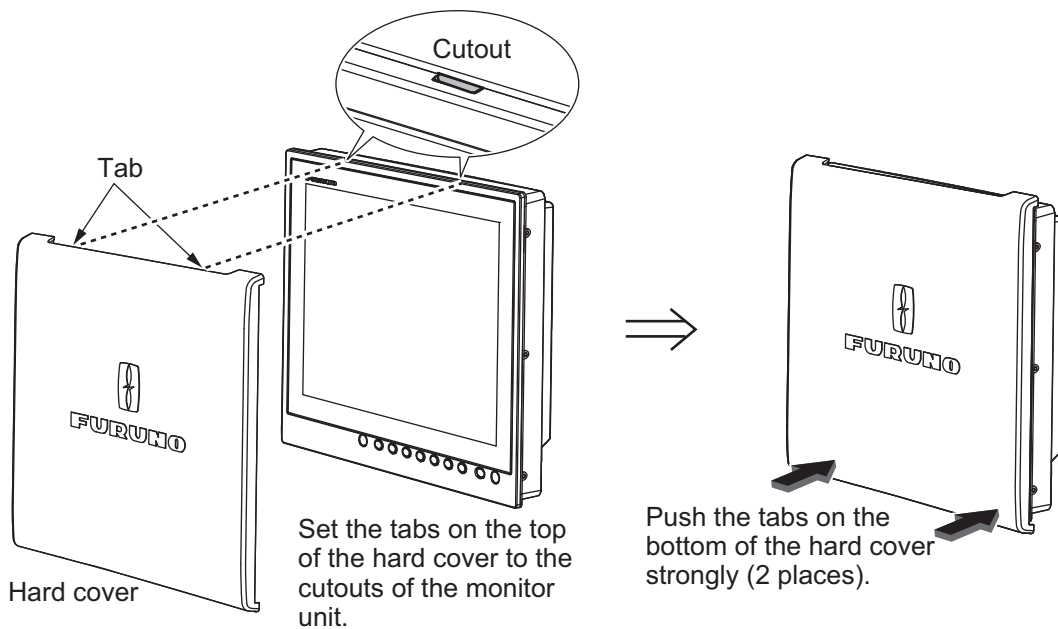

*How to attach the hard cover*

### Cable connection

Before you install the monitor unit, run and connect all cables you use. See the interconnection diagram at the back of this manual.

## 1.2 Flush Mounting, Fixed at Rear (Standard)

This is the standard installation method.

1. Make a cutout in the mounting location referring to the outline drawing at the back of this manual.
2. Attach the flush mounting sponges H15 and V15 in the order shown in the figure below.

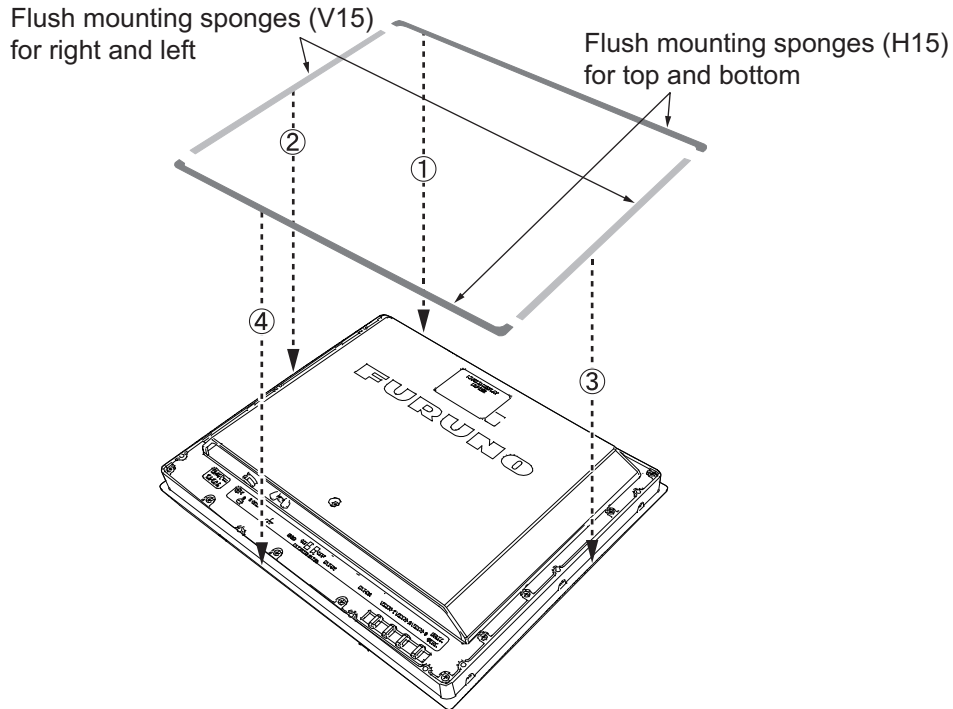

3. Connect all cables at the back of the monitor unit. See section 1.8.
4. Fit the monitor unit to the cutout.

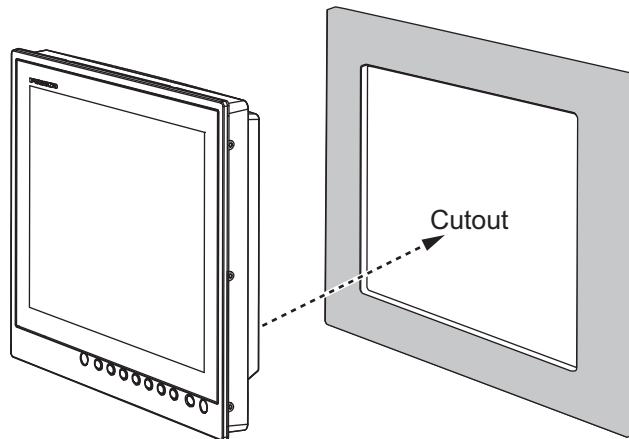

- Screw the wing bolts and the wing nuts of the flush mount fixture 15 so that the protector moves to the mount fixture.

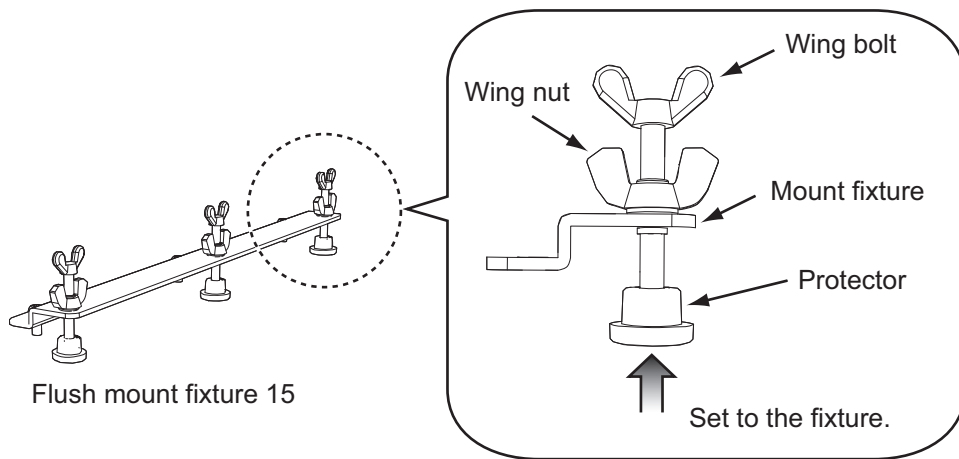

- Fasten the flush mount fixture 15 to the right and left sides of the rear of the monitor unit with the washer head screws (6 places).

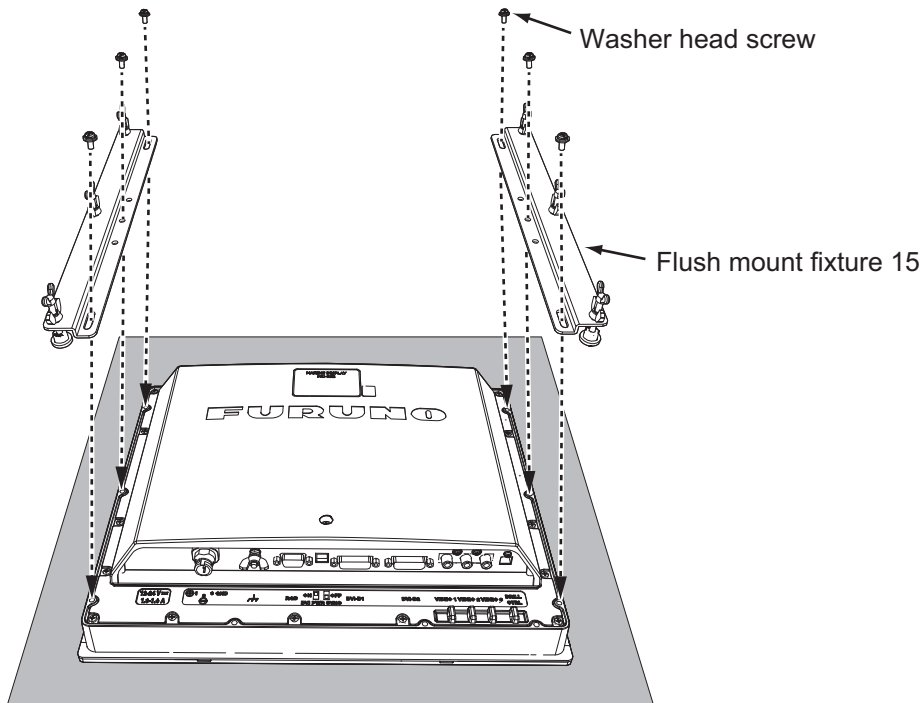

- Fasten the wing bolts, in the numerical order shown in the figure below so that the protectors touch the mounting panel.

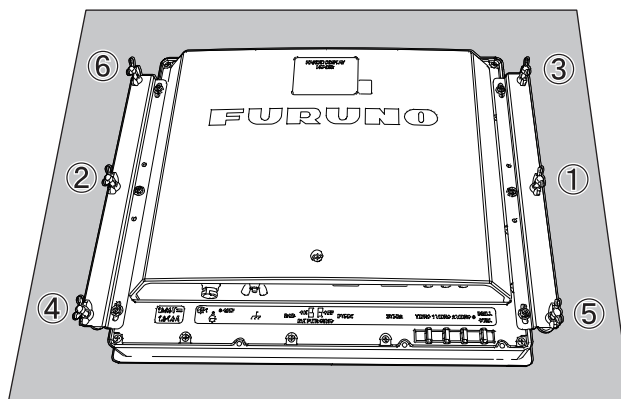

- Fasten the wing bolts tightly, in the numerical order shown in step 7.

1. MOUNTING, WIRING

9. Fasten the wing nuts tightly.

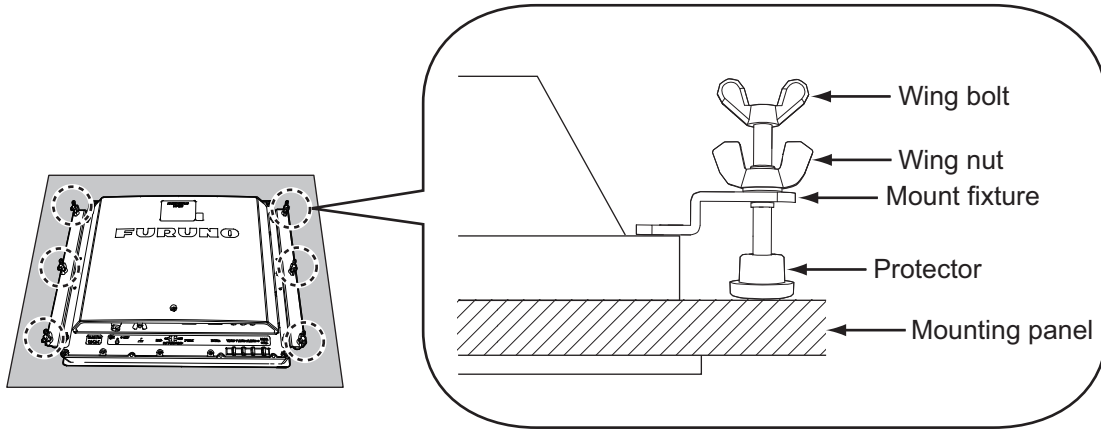

### 1.3 Flush Mounting, Fixed at Front (Option)

If you do not have the enough space to fix the monitor unit from the rear, you can fix it from the front with the flush mount kit OP26-36 (option).

Flush Mount Kit OP26-36

Name	Type	Qty.
Flush Mounting Panel (15)	OP26-36-1	1
Washer Head Screw	M4×10	8
Self Tapping Screw	5×20	4
Flush Mounting Template	C42-00909-B	1

1. Make a cutout in the mounting location with the flush mounting template (included).
2. Attach the flush mounting sponges H15 and V15 in the order shown in the figure below.

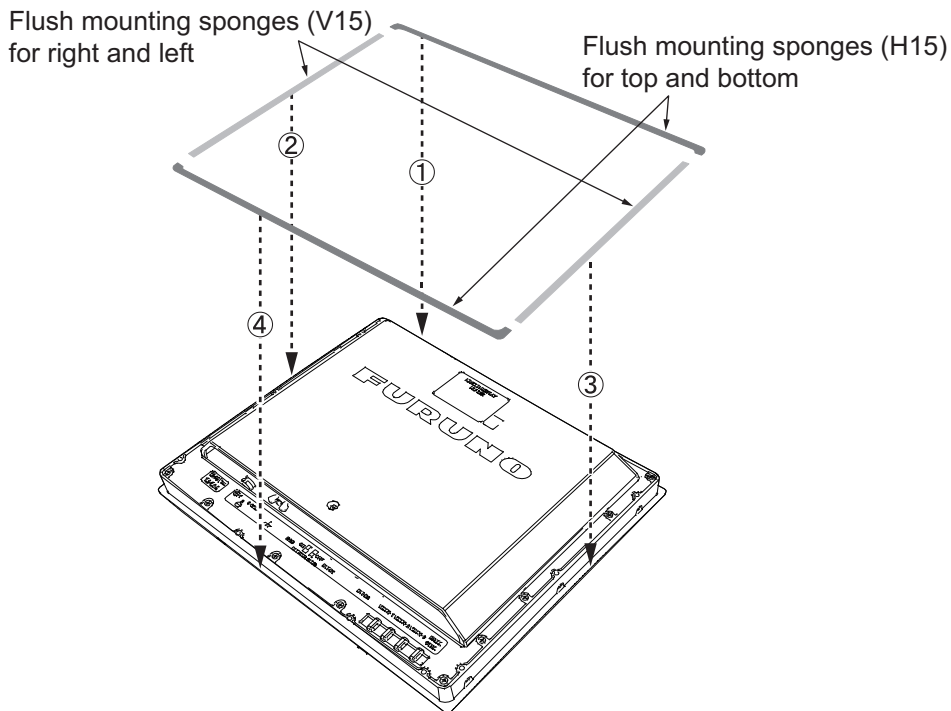

- Attach the flush mounting panel (15) to the monitor unit from the rear with the washer head screws (M4×10, 8 places, torque: 1.2 N·m). Do not confuse the top and bottom of the panel and check that screw holes on the panel and unit are aligned.

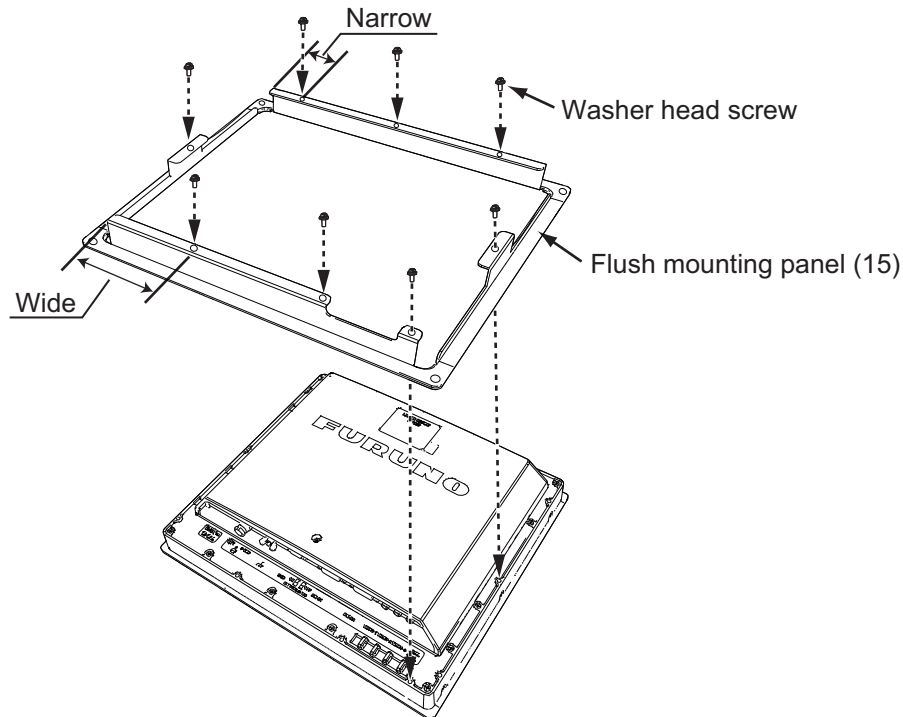

- Connect all cables at the back of the monitor unit. See section 1.8.
- Fit the monitor unit assembly to the cutout.
- Secure the monitor unit to the cutout with the self tapping screws (4 places).

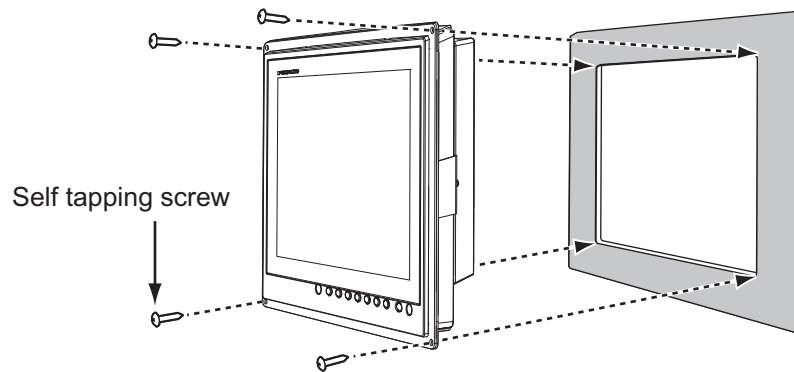

## 1.4 Desktop Mounting (Option)

You can mount the monitor unit on a desktop, using the bracket assembly OP26-35 (option).

### Bracket Assembly OP26-35

Name	Type	Qty.
Mounting Bracket (15)	OP26-2-1	1
Bracket Support w/knobs	OP26-35-1	
Self-Tapping Screw	5×20	4
Binding Head Screw	M4×10	6

## 1. MOUNTING, WIRING

1. Loosen the knobs of the bracket support to separate the mounting bracket (15) from the bracket support.

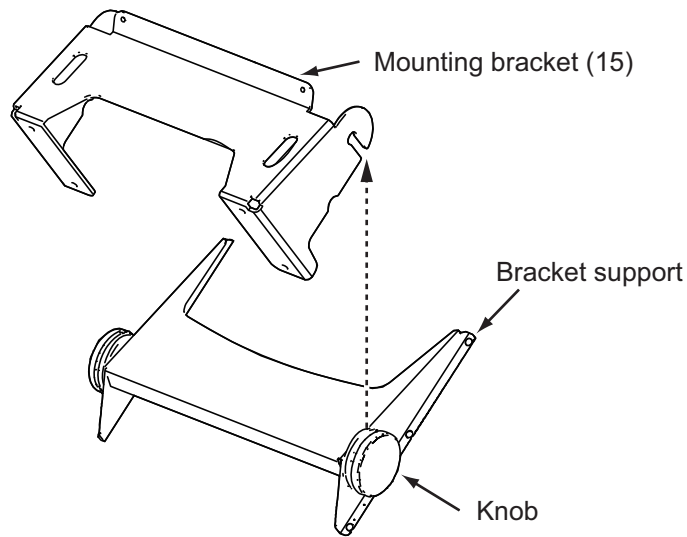

2. Secure the mounting bracket (15) to the mounting location with four self-tapping screws.

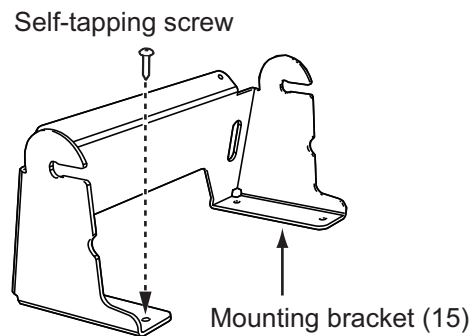

3. Attach the bracket support to the rear of the monitor unit with the binding head screws (M4×10, 6 places, torque: 1.2 N•m).

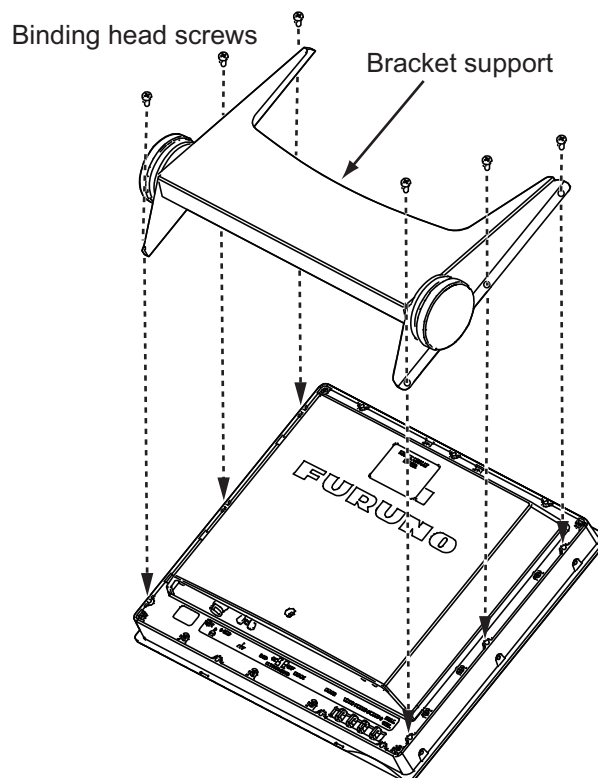

4. Connect all cables at the back of the monitor unit. See section 1.8.
5. Loosen the knobs of the bracket support and set them in the notches on the mounting bracket (15).

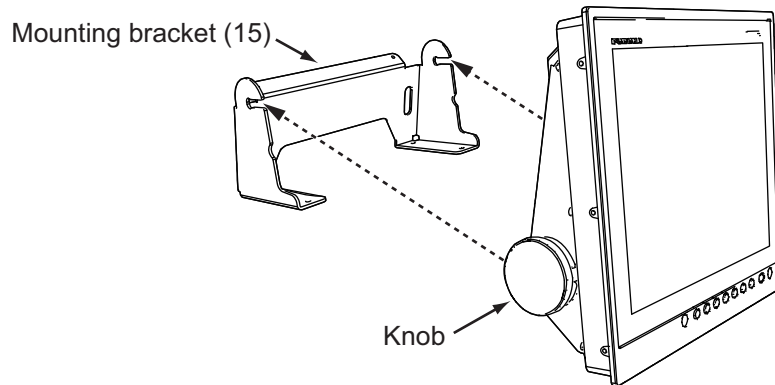

6. Adjust the angle of the monitor unit and fasten the knobs tightly.

## 1.5 Flush Mounting, Fixed at Rear, with Hood (Option)

You can attach a hood when flush mounting the unit from the rear, using the hood assembly OP26-3 (option).

### Hood Assembly OP26-3

Name	Type	Qty.
Hood (15) Assembly	OP26-3-1	1
Hood Fixing Plate 15	26-005-2302-1	2
F-Mount Hood Packing 15	26-005-2305	1
Hood Packing Bottom 15	26-005-2306	1
F-Mount Hood Packing Side 15	26-005-2307	2
Knob M4	03-163-2303-2	4
Flat Head Screw	M3×8	6
Flush Mounting Template	C42-00908-B	1

1. Make a cutout in the mounting location with the flush mounting template (included).
2. Attach the hood fixing plates 15 to the right and left of the monitor unit with flat head screws (M3×8, 6 places, torque: 0.6 N•m).

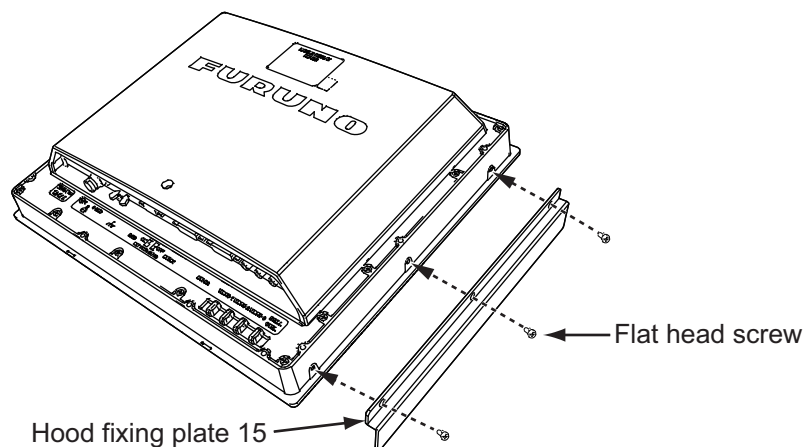

1. MOUNTING, WIRING

3. Attach the F-mount hood packing 15 to the top brim, the hood packing bottom 15 to the bottom brim, and then attach the F-mount hood packing side 15 to the right and left sides of the monitor unit from the rear side as shown the figure below.

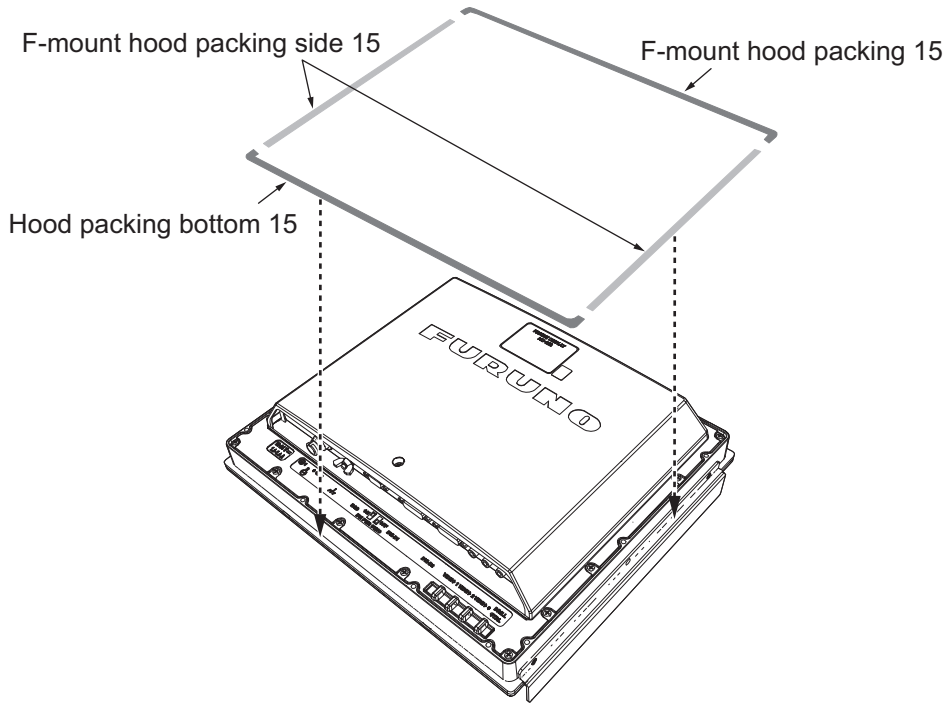

4. Follow steps 3 to 9 in section 1.2 to fit the monitor unit to the mounting location.  
5. Loosely fix the knobs M4 (4 pcs.) to the hood fixing plates 15.  
6. Slide the cutouts of the hood (15) assembly onto the knobs M4.

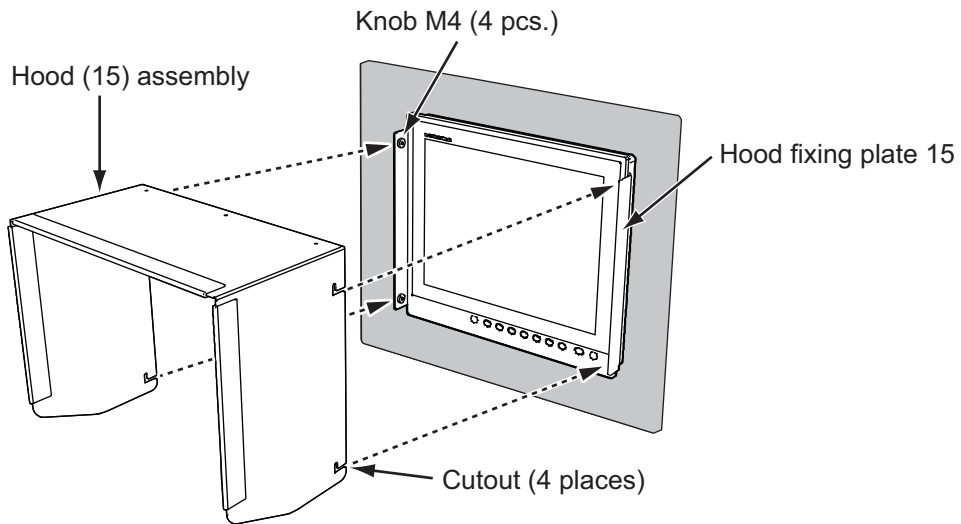

- Press the top of the hood (15) assembly to fit the knobs M4 in the cutouts.

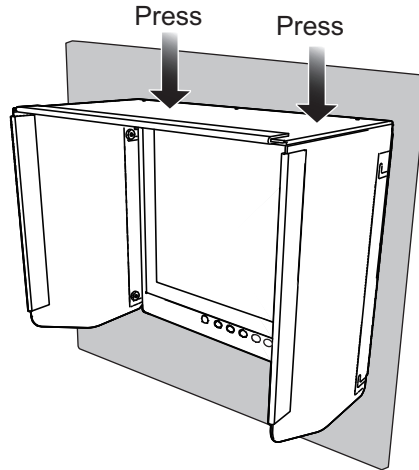

- Fasten the knobs (4 places) to secure the hood (15) assembly in place.

## 1.6 Desktop Mounting, with Hood (Option)

You can attach a hood when desktop mounting the unit, using the hood assembly OP26-3 (option) and the bracket assembly OP26-35 (option). See sections 1.4 and 1.5.

- Follow steps 1 to 3 in section 1.4.
- Follow steps 1 to 8 in section 1.5.
- Follow steps 5 and 6 in section 1.4.

## 1.7 Replacing the MU-151C with the MU-152

There are two methods to replace an existing flush mounted MU-151C with the MU-152; fixed from the front (requires the flush mount kit OP26-36, available as an optional extra), or fixed from the rear (without OP26-36). We recommend the flush mounting fixed at front to hide the screw holes.

### Fixing from the front

- Use the flush mounting template (included with the optional kit) to broaden the cutout at the mounting location.
- Follow steps 2 to 6 in section 1.3.

### Fixing from the rear

- Referring to the outline drawing at the back of this manual, broaden the cutout at the mounting location.
- Follow steps 2 to 9 in section 1.2.

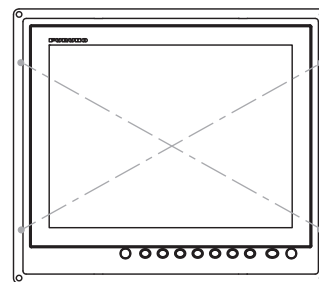

Screw holes of the MU-151C (• 4 places) are hidden with OP26-36.

Fixing from the front with OP26-36

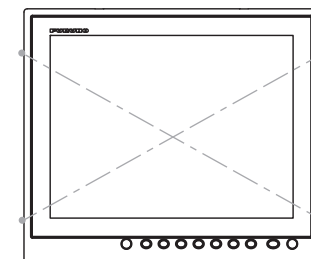

Screw holes of the MU-151C (• 4 places) are not hidden.

Fixing from the rear

## 1.8 Wiring

Refer to the figure below and the interconnection diagram at the back of this manual to connect cables.

### Connector

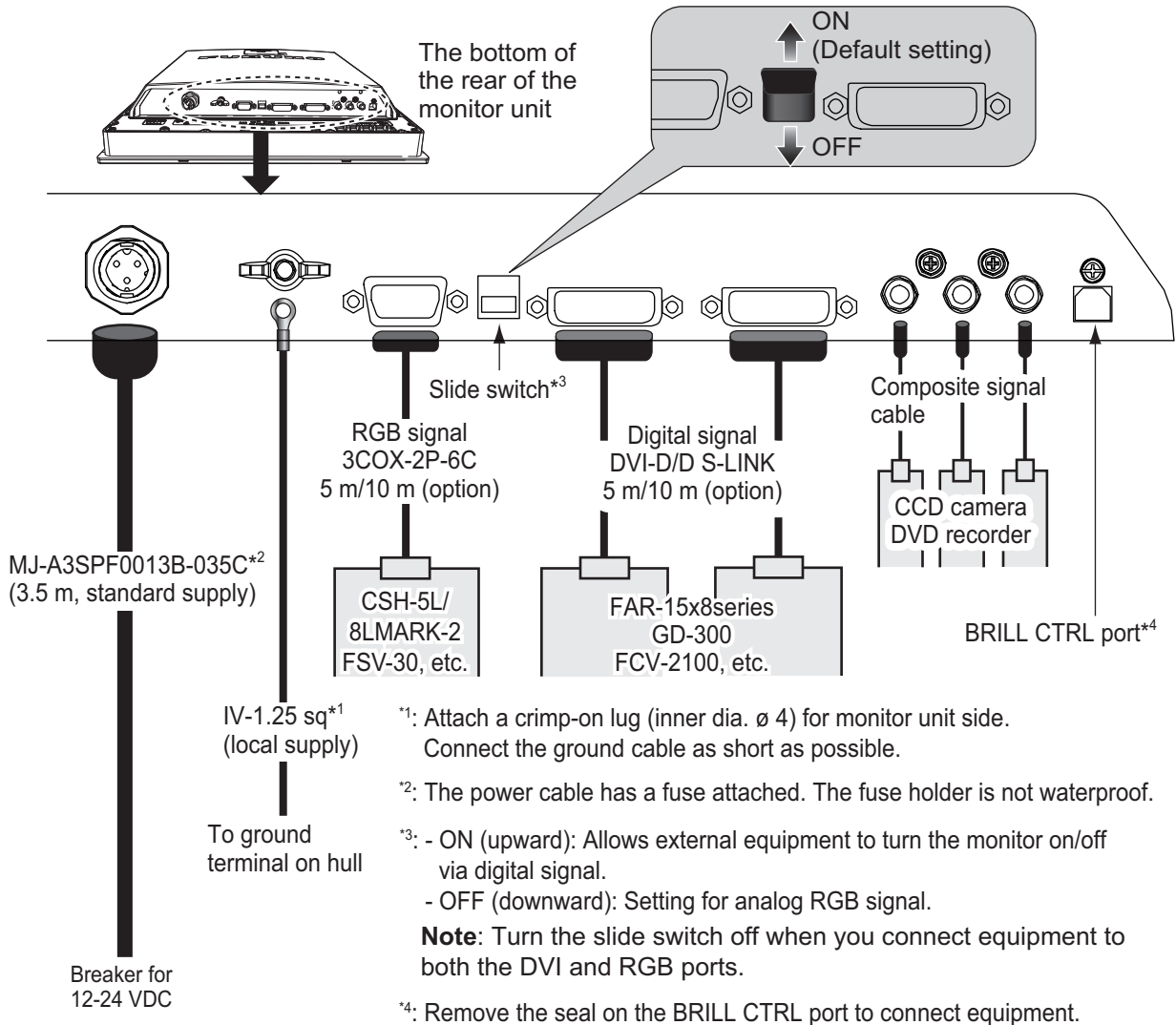

### How to secure composite signal cable

Secure composite cables with cable ties at the cable clamps, to prevent disconnection.

1. Pass the cable tie (supplied) through the side of the cable clamp.
2. Set the cable in the cable tie and fasten the cable tie.
3. Cut off excess cable tie with nippers.

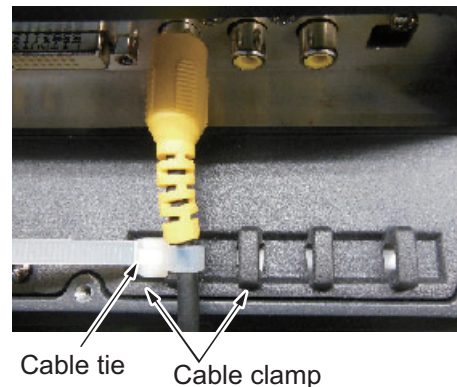

## 2. ADJUSTMENTS

Adjust the MU-152 according to the equipment connected.

### 2.1 RGB/DVI Setting

You can adjust the settings for the RGB, DVI-D1 and DVI-D2 ports individually. Turn on the external equipment and adjust the monitor unit as follows.

1. Select the signal to adjust at the DISP selection window. See section 3.4.
  - 1) Press the **DISP** key.
  - 2) Press the **▲** or **▼** key to select [RGB], [DVI1] or [DVI2].
2. Press the **MENU** key to show the menu. The menu closes automatically when there is no operation for one minute.
3. Press the **◀** or **▶** key to select [RGB], [DVI1] or [DVI2]. The current selection (the cursor) is shown in orange. The displayed menu items depend on the selected menu. The [DVI1] and [DVI2] menus show the same menu items.

**Note:** If there is no signal, menu items appear in gray and are not available.

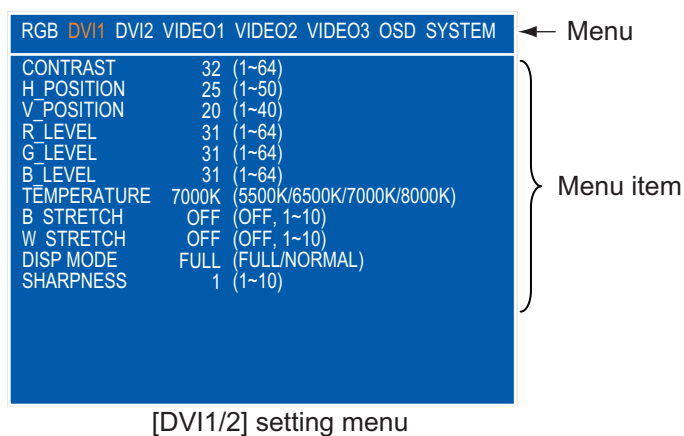
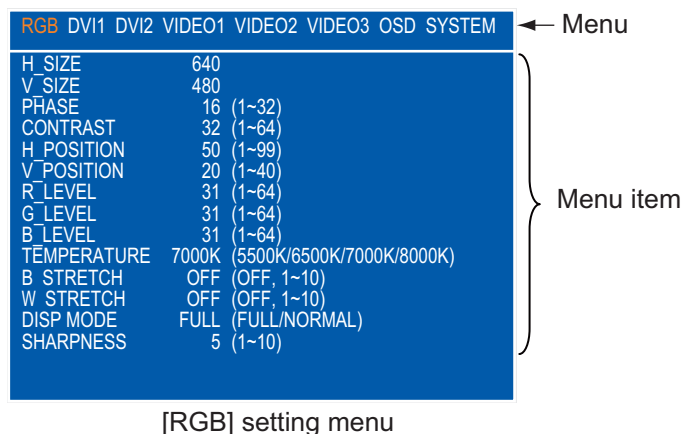

4. Press the **▲** or **▼** key to select the menu item to adjust.
5. Press the **◀** or **▶** key to adjust the setting.
6. Press the **MENU** key to close the menu.

## 2. ADJUSTMENTS

### [RGB], [DVI1/2] menu descriptions

Menu item	Function	Setting
[H_SIZE] (Only for [RGB] menu)	Adjusts the image size horizontally. Horizontal size: ◀ (narrow), ▶ (wide)	Depending on input signal
[V_SIZE] (Only for [RGB] menu)	Adjusts the image size vertically. Vertical size: ◀ (narrow), ▶ (wide)	
[PHASE]* (Only for [RGB] menu)	Adjusts the sample timing so that screen flicker disappears and the text is clear.	1 to 32
[CONTRAST]	Adjusts the contrast level. ◀ (darken), ▶ (brighten)	1 to 64
[H_POSITION]	Moves the image position horizontally. ◀ (leftward), ▶ (rightward)	1 to 99 ([RGB]), 1 to 50 ([DVI1], [DVI2])
[V_POSITION]	Moves the image position vertically. ◀ (upward), ▶ (downward)	1 to 40
[R_LEVEL]	Adjusts the red color level. ◀ (weaken), ▶ (strengthen)	1 to 64
[G_LEVEL]	Adjusts the green color level. ◀ (weaken), ▶ (strengthen)	1 to 64
[B_LEVEL]	Adjusts the blue color level. ◀ (weaken), ▶ (strengthen)	1 to 64
[TEMPERATURE]	Adjusts the color temperature. [5500K] (the most reddish), [8000K] (the most bluish)	5500K, 6500K, 7000K, 8000K
[B STRETCH]	Emphasizes the black color. [OFF] (standard), ◀ (weaken), ▶ (strengthen)	[OFF], 1 to 10
[W STRETCH]	Emphasizes the white color. [OFF] (standard), ◀ (weaken), ▶ (strengthen)	[OFF], 1 to 10
[DISP MODE]**	Selects the display method. [FULL]: Shows the input signal on entire screen. [NORMAL]: Shows the input signal with original aspect ratio.	[FULL], [NORMAL]
[SHARPNESS]*	Sharpens the edge horizontally. ◀ (soften characters and lines), ▶ (sharpens characters and lines)	1 to 10

\*: If the characters are not clear, adjust [PHASE] and [SHARPNESS].

\*\* : For SXGA input, a circle may be displayed as an ellipse because the aspect ratio differs. In this case, set [DISP MODE] to [NORMAL]. The right and left edges of the screen are left blank, but this is normal.

## 2.2 Video Composite Signal Setting

You can adjust the VIDEO1, 2 or 3 signal from the VIDEO1, VIDEO2 and VIDEO3 ports separately. The VIDEO1, 2 or 3 signal is also displayed in the PIP window (see section 3.5).

1. Select the signal to adjust at the DISP selection window (see section 3.4).
2. Press the **MENU** key to show the menu.
3. Press the ◀ or ▶ key to select [VIDEO1], [VIDEO2] or [VIDEO3]. The [VIDEO1], [VIDEO2] and [VIDEO3] menus show the same menu items.

RGB	DVI1	DVI2	VIDEO1	VIDEO2	VIDEO3	OSD	SYSTEM
PIP_SIZE			5	(1~10)			
CONTRAST			32	(1~64)			
R_LEVEL			31	(1~64)			
G_LEVEL			31	(1~64)			
B_LEVEL			31	(1~64)			
TEMPERATURE	7000K			(5500K/6500K/7000K/8000K)			
B STRETCH	OFF			(OFF, 1~10)			
W STRETCH	OFF			(OFF, 1~10)			

4. Press the ▲ or ▼ key to select the menu item to adjust.
5. Press the ◀ or ▶ key to adjust the setting.
6. Press the **MENU** key to close the menu.

### [VIDEO1/2/3] menu descriptions

Menu item	Function	Setting
[PIP_SIZE]	Adjusts the size of the picture-in-picture window. <b>Note:</b> This setting is available when the PIP window is displayed.	1 (47 mm×31 mm) to 10 (235 mm×160 mm)
[CONTRAST]	Adjusts the contrast level. ◀ (darken), ▶ (brighten)	1 to 64
[R_LEVEL]	Adjusts the red color level. ◀ (weaken), ▶ (strengthen)	1 to 64
[G_LEVEL]	Adjusts the green color level. ◀ (weaken), ▶ (strengthen)	1 to 64
[B_LEVEL]	Adjusts the blue color level. ◀ (weaken), ▶ (strengthen)	1 to 64
[TEMPERATURE]	Adjusts the color temperature. [5500K] (the most reddish), [8000K] (the most bluish)	5500K, 6500K, 7000K, 8000K
[B STRETCH]	Emphasizes the black color. [OFF] (standard), ◀ (weaken), ▶ (strengthen)	[OFF], 1 to 10
[W STRETCH]	Emphasizes the white color. [OFF] (standard), ◀ (weaken), ▶ (strengthen)	[OFF], 1 to 10

## 2.3 The Menu Window Setting

### 2.3.1 How to adjust the menu window

You can adjust the position and transparency of the menu window on the [OSD] (On Screen Display) menu.

1. Press the **MENU** key to show the menu.
2. Press the ◀ or ▶ key to select [OSD].

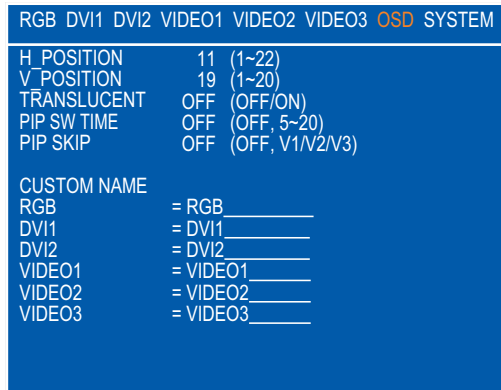

3. Press the ▲ or ▼ key to select the menu item to adjust.
4. Press the ◀ or ▶ key to adjust the setting.
5. Press the **MENU** key to close the menu.

#### [OSD] menu descriptions

Menu item	Function	Setting
[H_POSITION]	Moves the menu window horizontally. ◀ (leftward), ▶ (rightward)	1 to 29
[V_POSITION]	Moves the menu window vertically. ◀ (upward), ▶ (downward)	1 to 37
[TRANSLUCENT]	Adjusts the transparency of the background color (blue) on the menu window. [OFF]: Blue, [ON]: Translucent <b>Note:</b> Alpha blending technology is used for transparency effects.	[OFF], [ON]
[PIP SW TIME]	Switches the screen image on the PIP window among VIDEO1, VIDEO2 and VIDEO3 at the interval (5 to 20 seconds) selected here. When [OFF] is selected, the picture is not switched.	[OFF], 5 to 20
[PIP SKIP]	Selects which video signals to skip in the PIP window when [PIP SW TIME] is active. [OFF]: VIDEO1, VIDEO2 and VIDEO3 are shown in order. [V1]: VIDEO1 is skipped. VIDEO2 and VIDEO3 are shown alternately. [V2]: VIDEO2 is skipped. VIDEO1 and VIDEO3 are shown alternately. [V3]: VIDEO3 is skipped. VIDEO1 and VIDEO2 are shown alternately.	[OFF], [V1], [V2], [V3]
[CUSTOM NAME]	See section 2.3.2.	

### 2.3.2 How to change the signal name

You can change the signal name ([RGB], [DVI1/2] or [VIDEO1/2/3]) to a name which is easier to understand, such as the name of the connected equipment. The changed name is shown in the DISP selection window, PIP selection window and the indication shown at the upper right of the screen. See sections 3.4 and 3.5.

1. Press the **MENU** key to show the menu.
2. Press the ◀ or ▶ key to select [OSD].
3. Press the ▼ key to select the signal whose name you want to change. In the example below, [RGB] is selected.

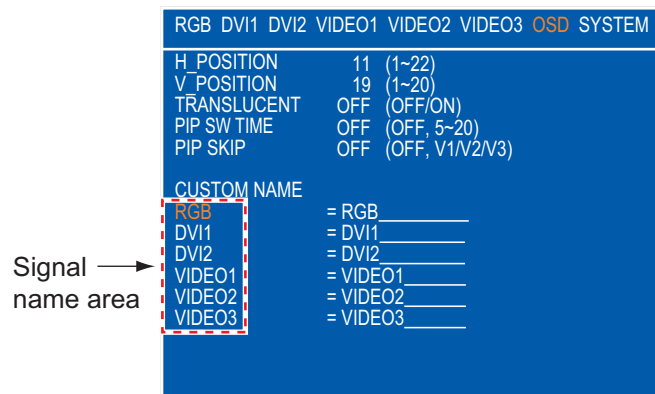

4. Press the ▶ key to select the character to change. In the example below, [G] of RGB is selected.

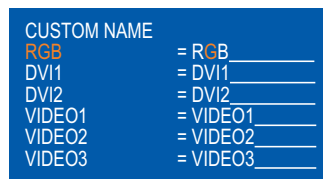

5. Press the ▲ or ▼ key to select an appropriate alphanumeric character. In the example below, [5] is selected. You can set up to ten characters. "A to Z", "0 to 9", "-", ".", " " (space) are available.

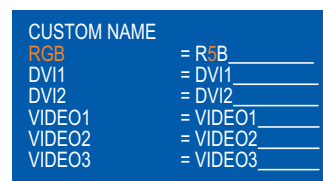

6. To change another signal name, press the ◀ key several times to return the cursor to the signal name area. Repeat steps 3 to 5.
7. Press the **MENU** key to close the menu.

# 3. OPERATION

## 3.1 Controls

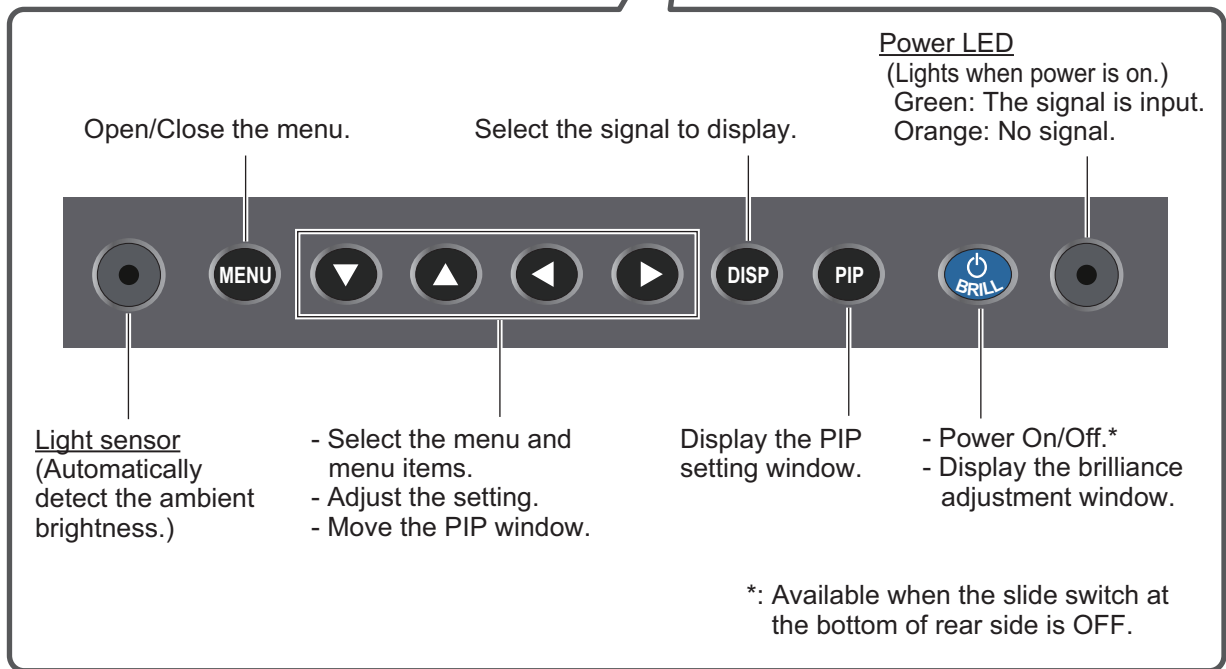
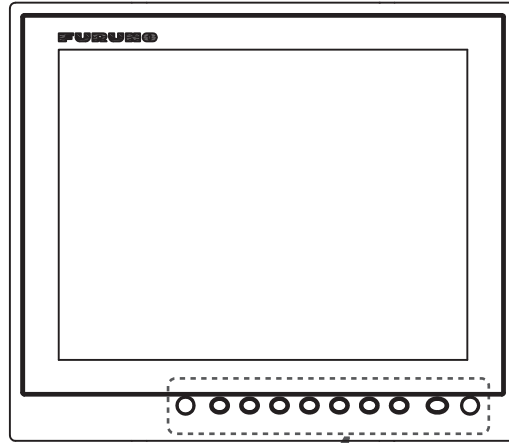

## 3.2 How to Turn the Power On/Off

This section shows how to turn on/off the monitor unit and the key lock function.

### 3.2.1 Turn the power on/off

How to turn on/off the power depends on the setting of the slide switch. The slide switch is set when the monitor unit is installed. See section 1.8.

**Note 1:** When you restart the monitor unit, wait at least three seconds before powering the unit.

**Note 2:** The screen refreshes slower in low ambient temperatures.

#### Slide switch “ON”

The external equipment connected to the DVI port (DVI-D1 or DVI-D2) can power on/off the monitor unit. See the external equipment’s operator’s manual.



**Note 1:** You can not turn on the power with the /BRILL key on the MU-152.

**Note 2:** When you connect the cables to both DVI-D1 and DVI-D2 ports, turn off the power of both connected equipment to turn off the monitor unit.

**Note 3:** When turning off the power with long press of the /BRILL key on the MU-152, do the following procedures to restart the MU-152.

- 1) Restart the equipment connected to the DVI-D1 or DVI-D2 port.
- 2) Disconnect the power cable from the MU-152, then connect it again.

#### Slide switch “OFF”

1. Press the /BRILL key to turn on the monitor unit.
2. Press and hold the /BRILL key for three seconds to turn off the monitor unit. While you hold the key, the indication shown in the figure to the right appears.



SHUT DOWN  
This monitor will shut down in three seconds.

### 3.2.2 Lock the key operation

You can lock the monitor unit to prevent operation. Any key (except the /BRILL key) will be inoperative.



1. While you hold the **PIP** key, turn on the monitor unit. Keep the **PIP** key pressed for more than five seconds.  
**Note:** When the slide switch is ON, turn on the connected external equipment while pressing the **PIP** key to turn on the monitor unit.
2. To cancel the lock, turn off the monitor unit and then turn it on while you hold the **PIP** key. Keep the **PIP** key pressed for more than five seconds.

**Note:** The menu is not displayed when the monitor unit is locked. All menu settings retain their value from before the monitor unit is locked.

### 3.3 How to Adjust the Display Brilliance

You can adjust the display brilliance as follows:

**Note:** This function is available when [AUTO DIMMER] and [EXT BRILL CTRL] on the [SYSTEM] menu are set to [OFF]. See section 3.6.1.

1. Press the /BRILL key momentarily to show the BRILL adjustment window. The window closes automatically when there is no operation for five seconds.
2. Press the ◀ or ▶ key to adjust the brilliance. You can also adjust the brilliance by pressing the /BRILL key repeatedly. The setting range is 1 to 50 (default: 50).
3. Press the ▲ or ▼ key to close the window.

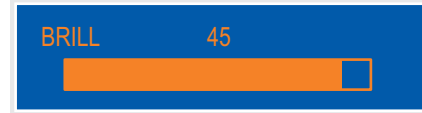

**Note 1:** If you turn off the monitor unit with the minimum brilliance, it may be difficult to see the screen when you next turn the power on, due to ambient light. In this case, press the /BRILL key repeatedly.

**Note 2:** When connecting the MU-152 to the FAR-15x3/15x8, FAR-1417/1427 or FCV-1900, you can adjust the display brilliance from the equipment's control unit. See section 3.6.2.

### 3.4 How to Select the Source for Main Picture

Select the signal to display on the entire screen as follows:

1. Press the DISP key to show the DISP selection window. The signal names are shown as customized at section 2.3.2 on the window. The window closes automatically when there is no operation for five seconds.
2. Press the ▲ or ▼ key to select a signal. You can also select the signal by pressing the DISP key continuously.

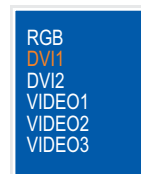

[RGB]: The signal from the RGB port is displayed.  
 [DVI1], [DVI2]: The signal from the selected DVI port is displayed.  
 [VIDEO1] to [VIDEO3]: The external video from the selected VIDEO port is displayed.

3. Press the ◀ or ▶ key to close the window. The name of the selected signal appears at the top right of the screen for five seconds after the DISP selection window disappears. If there is no signal, "NO SIGNAL" appears.

### 3.5 How to Display the PIP Window

The PIP (picture-in-picture) window, which displays the picture input to the VIDEO port, is available on the RGB, DVI1 and DVI2 displays.

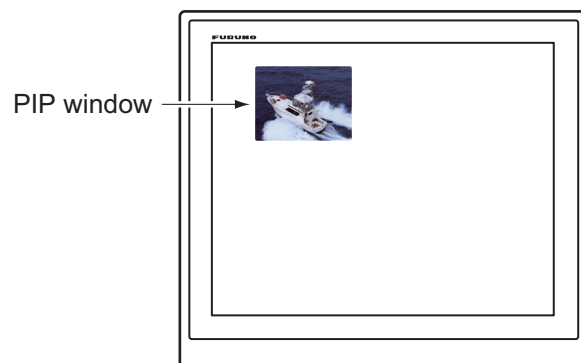

1. When the RGB, DVI1 or DVI2 display appears, press the **PIP** key to show the PIP selection window. The signal names appear with their customized name (see section 2.3.2). The window closes automatically when there is no operation for five seconds.
2. Press the ▲ or ▼ key to select the VIDEO port required. [VIDEO1] (2 or 3) can also be selected by pressing the **PIP** key continuously. When you select the [VIDEO1], [VIDEO2] or [VIDEO3], the PIP window is displayed. To close the PIP window, select [OFF].
3. Press the ◀ or ▶ key to close the PIP selection window.
4. You can move the PIP window by pressing the arrow keys when the menu is closed. Press and hold the arrow keys to move the PIP window quickly.

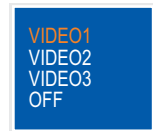

**Note 1:** To show the VIDEO1, VIDEO2 and VIDEO3 pictures alternately, set the cycle time (5 to 20 sec) with [PIP SW TIME] on the [OSD] menu. In this case, the above setting is invalid. See section 2.3.1.

**Note 2:** You can adjust the size of the PIP window on the [VIDEO1] (2 or 3) menu(s). See section 2.2.

## 3.6 SYSTEM Menu

You can set the brilliance control and clear the memory on the [SYSTEM] menu. Also, you can check signal status, the program number and the elapsed time (total time since first use) on the [SYSTEM] menu.

### 3.6.1 How to set the auto dimmer

The auto dimmer feature automatically adjusts the brilliance according to the ambient brightness detected by the light sensor on the front panel. Also, you can select the intervals at which the brilliance is adjusted.

**Note:** Do not put any objects in front of the light sensor.

1. Press the **MENU** key to show the menu.
2. Press the ▶ key to select [SYSTEM]. The message "Input Signal Searching Please Wait" is displayed and then the [SYSTEM] menu shown in the figure below is displayed.



Signal status, model type, program number and elapsed time

3. Press the ▼ key to select [AUTO DIMMER].
4. Press the ◀ or ▶ key to select the adjustment interval.
  - [OFF]: Disable this function.
  - [1]: Every two seconds
  - [2]: Every 30 seconds
  - [3]: Every minute
  - [4]: Every three minutes
  - [5]: Every five minutes
5. Press the **MENU** key to close the menu.

### 3. OPERATION

#### 3.6.2 How to adjust the brilliance from the external equipment

When the FAR-15x3/15x8 is connected to the DVI-D1 or DVI-D2 port, or the FAR-1417/1427 or FCV-1900 is connected to the USB port, you can adjust the display brilliance from the connected equipment.

**Note 1:** This function is available when [AUTO DIMMER] on the [SYSTEM] menu is set to [OFF].

**Note 2:** The FAR-1417/1427 is for Japan only.

1. Press the **MENU** key to show the menu.
2. Press the **▶** key to select [SYSTEM].
3. Press the **▼** key to select [EXT BRILL CTRL].
4. Press the **◀** or **▶** key to set the desired input item.

[OFF]: You can not adjust the brilliance from the external equipment.

[DVI1]: When the DVI1 is displayed, the brilliance signal from DVI-D1 port controls this display's brilliance. The **⏻/BRILL** key is available for screens other than the screen input from DVI1.

[DVI2]: When the DVI2 is displayed, the brilliance signal from DVI-D2 port controls this display's brilliance. The **⏻/BRILL** key is available for screens other than the screen input from DVI2.

[USB]: The brilliance signal from USB port controls this display's brilliance. The **⏻/BRILL** key is not available.

5. Press the **MENU** key to close the menu.

#### 3.6.3 How to clear the memory

You can clear the memory to restore the default settings.

1. Press the **MENU** key to show the menu.
2. Press the **▶** key to select [SYSTEM].
3. Press the **▼** key to select [DEFAULT RESET].
4. Press the **▶** key. The indication changes from [NO] to [YES].

RGB	DVI1	DVI2	VIDEO1	VIDEO2	VIDEO3	OSD	SYSTEM
AUTO DIMMER	OFF		(OFF, 1~5)				
EXT BRILL CTRL	OFF		(OFF/DVI1/DVI2/USB)				
DEFAULT RESET	YES						
All custom settings will be lost.							
←key: cancel →key: reset							
INFORMATION							
RGB	: 1280*1024		Fh : 80kHz		Fv : 75Hz		
DVI1	: 640*480		Fh : 31kHz		Fv : 60Hz		
DVI2	: NO SIGNAL						
VIDEO1	: NTSC						
VIDEO2	: PAL						
VIDEO3	: NO SIGNAL						
MODEL TYPE	: MU-152						
PROGRAM NO.	: XX.XX						
ELAPSED TIME	: 100000 hour						

**Note:** To cancel, press the **◀** key. The indication changes from [YES] to [NO].

5. Press the **▶** key to select [reset].

# 4. MAINTENANCE, TROUBLESHOOTING

---

## NOTICE

**Do not apply paint, anti-corrosive sealant or contact spray to coating or plastic parts of the equipment.**

Those items contain organic solvents that can damage coating and plastic parts, especially plastic connectors.

## 4.1 Maintenance

### Routine maintenance

Regular maintenance is important for good performance. Check the following on a regular basis to keep the equipment in good condition.

- Check that the connectors at the bottom of the monitor unit are tightly fastened.
- Check the ground wire and ground terminal for rust. Clean if necessary. Confirm that the ground wire is tightly fastened.
- Remove dust and dirt from the monitor unit with a dry, soft cloth. Do not use chemical cleaners to clean any part of the monitor unit. They can remove paint and markings.
- Check the dust or dirt is not on the display. Wipe it carefully to prevent scratching. For difficult to remove dirt or salt deposits, use a cloth made wet with water and neutral detergent (less than 1% detergent). Squeeze the cloth dry then clean the display. When the display is clean, gently wipe the display with a clean, soft, dry cloth, to prevent scratching.

### Fuse replacement

The fuse in the fuse holder on the power cable protects the equipment from overvoltage and overcurrent. If the fuse blows, find the cause before you replace it. If the fuse blows again after replacement, contact your dealer.

## **WARNING**

**Use the proper fuse.**

Use of a wrong fuse can cause fire or damage to the equipment.

Name	Type
Fuse	FGBO-A 125V 3A PBF

### LCD replacement

The life of the LCD is approximately 100,000 hours. The actual numbers of hours depends on ambient temperature and humidity. When the brilliance cannot be raised sufficiently, contact your dealer to request replacement of the LCD.

#### 4. MAINTENANCE, TROUBLESHOOTING

### **Fan replacement**

The life of the fan is approximately 95,000 hours. The actual numbers of hours depends on ambient temperature. When the fan cannot be rotated sufficiently, the message "FAN ERROR" is shown for 10 seconds after approx. 30 seconds from power-on. Turn off the power and contact your dealer to request replacement of the fan.

**Note:** When replacing the fan, check the mounting direction of fan referring to the figure below(rear inside view).

Name	Type
Fan Motor Assembly	109P0512H728

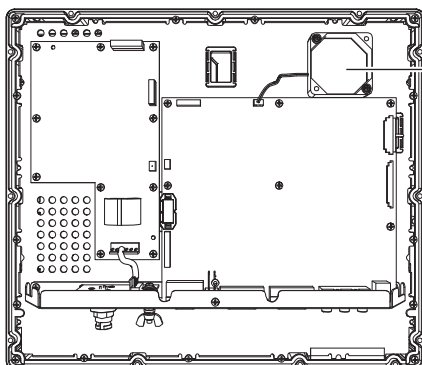

Fix the fan so that the label on the fan is directed downward, that is to the screen side.

## 4.2 Troubleshooting

See the following table to find the possible causes and the actions to restore normal operation. If repair of the equipment is necessary, contact your dealer and report the result of the troubleshooting to the serviceman.

### Troubleshooting

Case	Remedy
You can not turn on the power.	<ul style="list-style-type: none"> <li>• Check the setting for the slide switch. See section 1.8.</li> <li>• Check the battery voltage with a multimeter.</li> <li>• Check the fuse on the power cable.</li> <li>• Fasten the power cable tightly.</li> </ul>
You can not turn off the power.	<ul style="list-style-type: none"> <li>• Press and hold the /BRILL key for eight seconds.</li> <li>• When the slide switch is set to ON, turn off the connected external equipment.</li> </ul>
No picture	<ul style="list-style-type: none"> <li>• Fasten the cables tightly.</li> <li>• Check the input signal. See section 3.6.</li> <li>• Check the setting for DISP selection window. See section 3.4.</li> <li>• Check if the display brilliance is not set to minimum.</li> </ul>
You can not operate any key except the /BRILL key.	Cancel the key lock function. See paragraph 3.2.2.
The small rectangular frame in black is displayed on the screen.	Press the <b>PIP</b> key then select [OFF].

# APPX. 1 ABBREVIATIONS

	Abbreviation	Meaning
A	APR	Application Program
	AUTO	Automatic
B	B	Black
	BRILL	Brilliance
C	CCD	Charge-Coupled Device
	CH	Type of FURUNO searchlight sonar
	CI	Type of FURUNO current indicator
	CSH	Type of FURUNO color scanning sonar
	CTRL	Control
D	DISP	Display
	DVD	Digital Versatile Disc
	DVI	Digital Visual Interface
E	EXT	External
F	FAR	Type of FURUNO radar
	FCV	Type of FURUNO fish finder
	Fh	Horizontal Frequency
	FSV	Type of FURUNO color scanning sonar
	Fv	Vertical Frequency
G	GD	Type of FURUNO color video plotter
H	H	Horizontal
L	LCD	Liquid Crystal Display
	LED	Light-Emitting Diode
N	NO.	Number
	NTSC	National Television System Committee
O	OSD	On-Screen Display
P	PAL	Phase Alternating Line
	PC	Personal Computer
	PIP	Picture-in-Picture
Q	Qty	Quantity
R	RGB	Red/Green/Blue
S	SW	Switch
	SXGA	Super Extended Graphics Array (1280×1024)
U	USB	Universal Serial Bus
V	V	Vertical
	VGA	Video Graphics Array (640×480)
W	W	White
X	XGA	Extended Graphics Array (1024×768)

## Units of measurement

Abbreviation	Meaning	Abbreviation	Meaning
A	Ampere(s)	mm	Millimeter(s)
Hz	Hertz(es)	pc.	Piece
K	Kelvin	pcs.	Pieces
kHz	Kilohertz(es)	V	Volt(s)
m	Meter(s)		

## **SPECIFICATIONS OF MONITOR UNIT MU-152**

### **1 GENERAL**

1.1	Screen type	15-inch color LCD, 1024 x 768 (XGA)
1.2	Effective area	304 x 228 mm approx.
1.3	Pixel pitch	0.297 mm (Horizon/Vertical)
1.4	Brightness	400 cd/m <sup>2</sup> typical
1.5	Contrast	900: 1
1.6	View angle	80° or more (left/right and up/down)
1.7	Visible distance	1.02 m nominal
1.8	Input signal	
	RGB analog	1 port, Non-interlace, RGB signal: 0.7 Vp-p, Sync. signal: TTL level
	DVI-D	2 port, DVI-standard, VESA DDC2B
	Composite	3 port, NTSC/PAL-standard, Video signal: 0.7 Vp-p, Sync. signal: 0.3 V
	USB	1 port, USB1.1, 12Mbps, for brilliance control

### **2 POWER SUPPLY**

12-24 VDC (10.8-31.2 V): 1.9-0.9 A

### **3 ENVIRONMENTAL CONDITION**



3.1	Ambient temperature	-15°C to +55°C
3.2	Relative humidity	93% at +40°C
3.3	Degree of protection	IP56 (CFR46, front panel), IP22 (chassis)
3.4	Vibration	IEC60945 Ed.4

### **4 UNIT COLOR**

N2.5

**FURUNO**

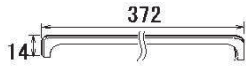
CODE NO.	001-497-440-00	26AN-X-9401 -1
TYPE	CP26-02401	1/1

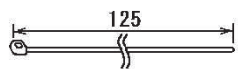
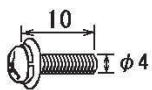
工事材料表 INSTALLATION MATERIALS		MU-152			
番号 NO.	名称 NAME	略図 OUTLINE	型名/規格 DESCRIPTIONS	数量 Q'TY	用途/備考 REMARKS
1	Fマウントスポンジ H15 FLUSH MOUNTING SPONGE H 15		26-005-2123-1	2	
			CODE NO. 100-351-281-10		
2	Fマウントスポンジ V15 FLUSH MOUNTING SPONGE V 15		26-005-2124-0	2	
			CODE NO. 100-351-290-10		
3	コンベックス CABLE TIE		CV-125N	4	
			CODE NO. 000-172-164-10		
4	ワッシャーヘッドネジ WASHER HEAD SCREW *B*		M4X10 SUS304	6	
			CODE NO. 000-163-836-10		

(略図の寸法は、参考値です。 DIMENSIONS IN DRAWING FOR REFERENCE ONLY.)



表1 TABLE 1

寸法区分 (mm) DIMENSION	公差 (mm) TOLERANCE
L ≤ 50	±1.5
50 < L ≤ 100	±2.5
100 < L ≤ 500	±3

表2 TABLE 2

フード、ガラス押え HOOD/FIXTURE	B (mm)	D (mm)
なし BLANK	6	364
あり ATTACHED	7	368

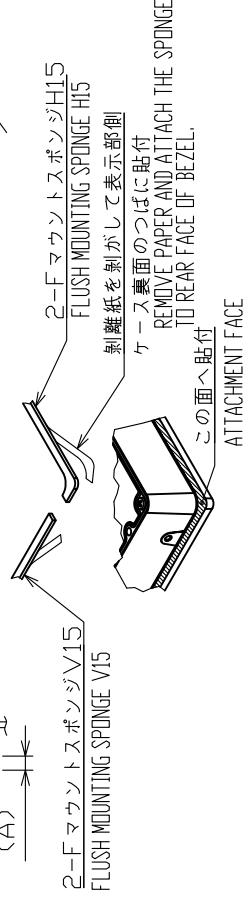
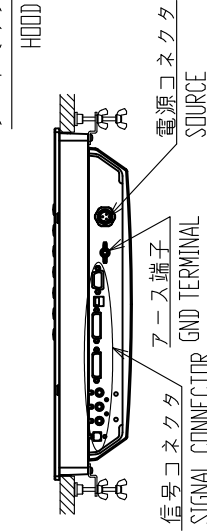
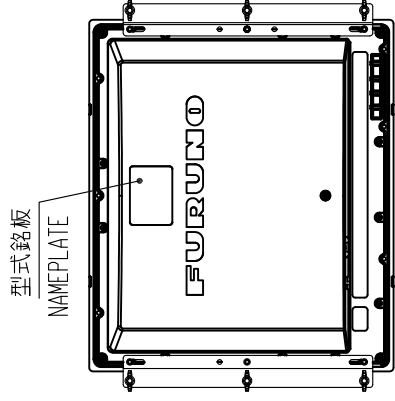
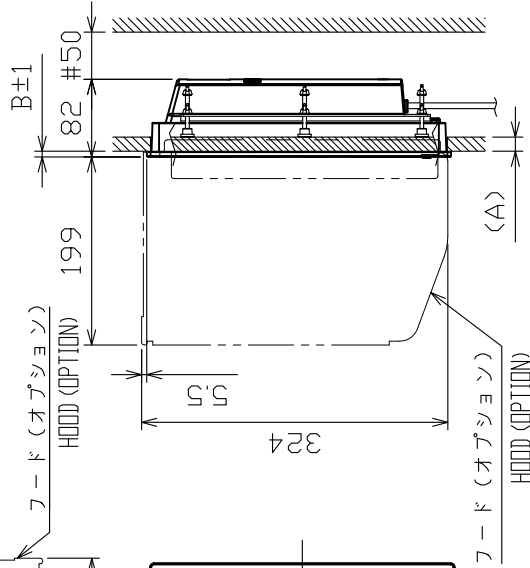
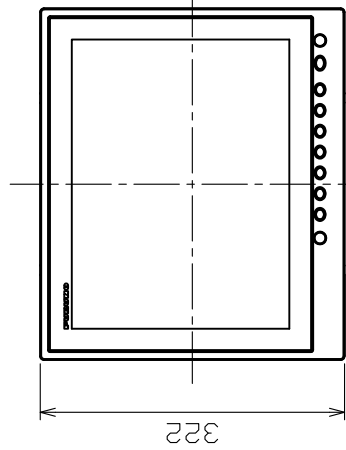
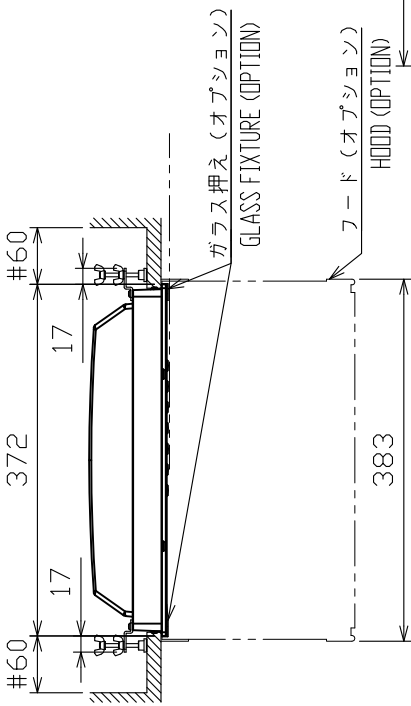
注 記

- 1) 指定外の寸法公差は表 1 による。
- 2) # 印寸法は最小サービスイ間寸法とする。
- 3) 壁の厚さ (A) は最少 10mm、最大 20mm とする。

NOTE

1. TABLE 1 INDICATES TOLERANCE OF DIMENSIONS WHICH IS NOT SPECIFIED.
2. #: MINIMUM SERVICE CLEARANCE.
3. BULKHEAD THICKNESS (A): 10 ≤ A ≤ 20.

DRAWN	5/Jul/2019	I.YAMASAKI	TITLE	MU-152
CHECKED	5/Jul/2019	H.MAKI	名称	表示部 (埋込装備 S)
APPROVED	8/Jul/2019	H.MAKI	外寸図	
SCALE	1/8	MASS 4.9 10% LOG	質量はオプションを含みます。 MASS DOES NOT INCLUDE OPTION.	MONITOR UNIT (FLUSH MOUNT S)
FIG.No.	C4497-601-C	REF.No.	26-010-1000-4	OUTLINE DRAWING



表1 TABLE 1

寸法区分 (mm) DIMENSION	公差 (mm) TOLERANCE
L ≤ 50	±1.5
50 < L ≤ 100	±2.5
100 < L ≤ 500	±3

ガラス押え (オプション)  
GLASS FIXTURE (OPTION)

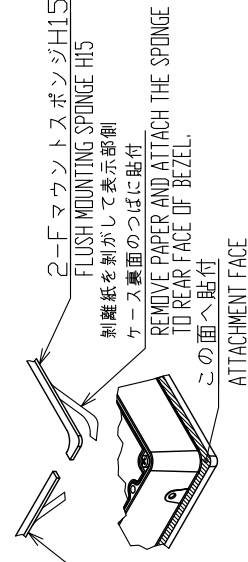
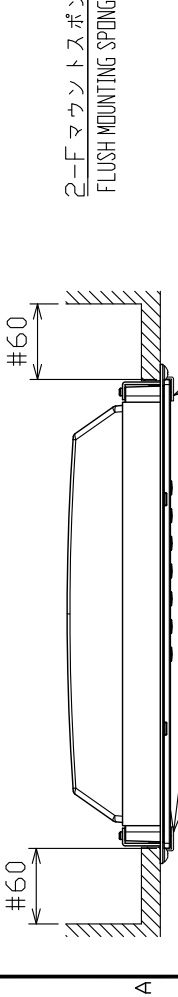
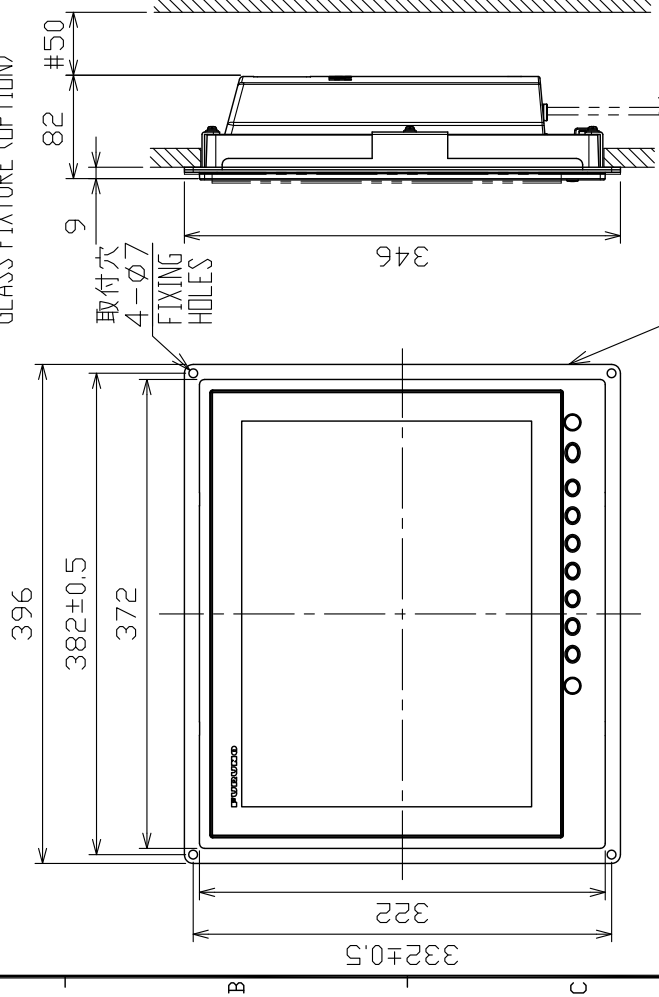

付属スポンジの貼付方法  
SPONGE ATTACHMENT METHOD

4-取付穴位置  
PILOT HOLES

型式銘板  
NAMEPLATE

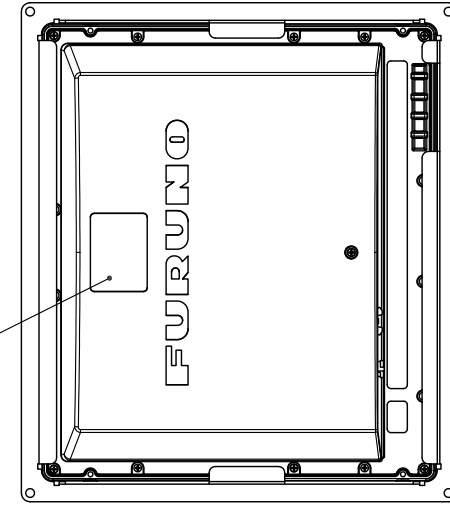

取付穴寸法  
CUTOUT DIMENSIONS

前面固定用パネル (オプション)  
COSMETIC PANEL (OPTION)

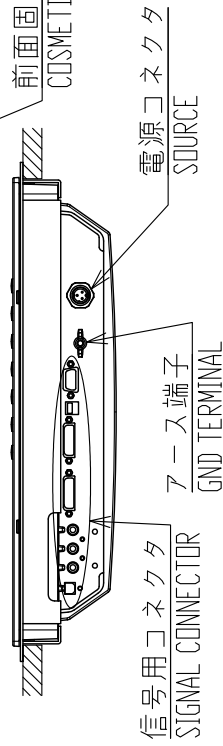

- NOTE
1. TABLE 1 INDICATES TOLERANCE OF DIMENSIONS WHICH IS NOT SPECIFIED.
  2. # MINIMUM SERVICE CLEARANCE.
  3. USE TAPPING SCREWS  $\phi 5 \times 20$  FOR FIXING THE UNIT.

DRAWN	5/Jul/2019	I. YAMASAKI	TITLE	MU-152
CHECKED	5/Jul/2019	H. MAKI	名称	15型カラー-LCD表示器 (埋込装備F)
APPROVED	8/Jul/2019	H. MAKI	外寸図	
SCALE	1/6	W/SS 4.9 100% W/O/OPTION	W/M/E	MARINE DISPLAY (FLUSH MOUNT F)
IMG.No.	C4497-603-C	REF.No.	26-010-1205-4	OUTLINE DRAWING

- 注 記
- 1) 指定外の寸法公差は表 1 による。
  - 2) # 印寸法は最小サービスイ間寸法 (最小配線寸法) とする。
  - 3) 取付用ネジはトラススタップピンネジ呼び径  $5 \times 20$  を使用のこと。

表1 TABLE 1

寸法区分 (mm) DIMENSION	公差 (mm) TOLERANCE
L ≤ 50	±1.5
50 < L ≤ 100	±2.5
100 < L ≤ 500	±3

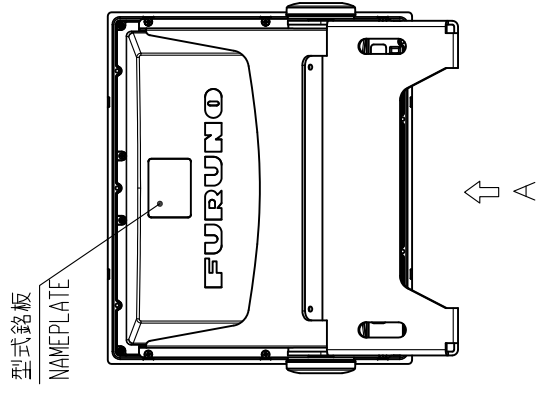
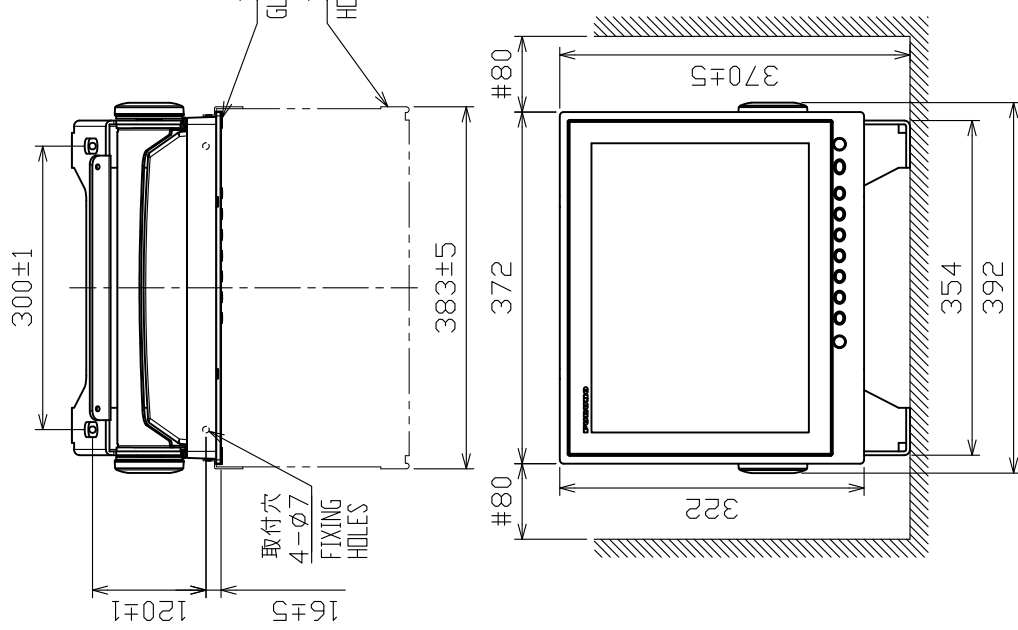
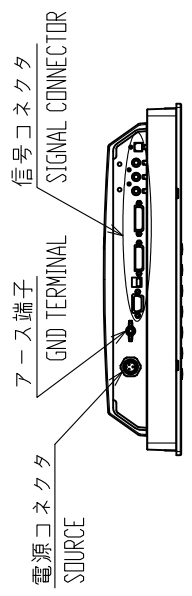

注記

- 1) 指定外の寸法公差は表1による。
- 2) #印寸法は最小サービス空間寸法とする。
- 3) 取付用ネジはトラスタックピンネジ呼び径5×20を使用のこと。

NOTE

1. TABLE 1 INDICATES TOLERANCE OF DIMENSIONS WHICH IS NOT SPECIFIED.
2. # MINIMUM SERVICE CLEARANCE.
3. USE TAPPING SCREWS  $\phi 5 \times 20$  FOR FIXING THE UNIT.

DRAWN	5/Jul/2019	I.YAMASAKI	TITLE	MU-152
CHECKED	5/Jul/2019	H.MAKI	名称	表示部 (卓上装備)
APPROVED	8/Jul/2019	H.MAKI	外寸図	
SCALE	1/8	質量 6.9 kg 質量はオプションを含みます。 MASS DOES NOT INCLUDE OPTION.	NAME	MONITOR UNIT (TABLETOP MOUNT)
IMG No.	C4497-602-C	REF.No.	26-010-1105-4	OUTLINE DRAWING

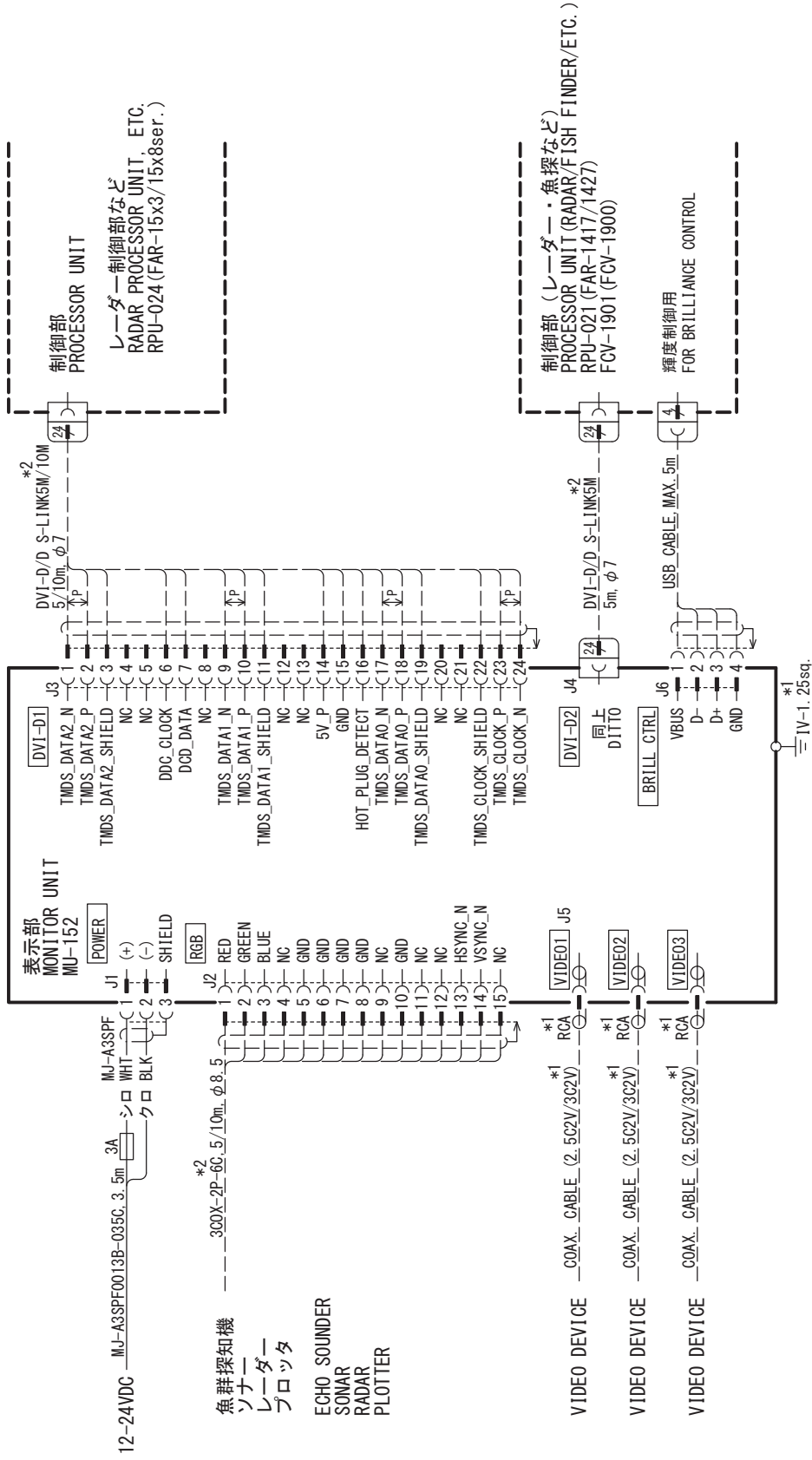

注記  
 \*1) 造船所手配。  
 \*2) オプション。

NOTE  
 \*1: SHIPYARD SUPPLY.  
 \*2: OPTION.

DRAWN	7/Mar/2024	T. YAMASAKI	TITLE	MU-152
CHECKED	7/Mar/2024	A. MURAO	名称	表示部
APPROVED	16/Mar/2024	A. MURAO	相互結線図	MONITOR UNIT
SCALE		MASS	kg	INTERCONNECTION DIAGRAM
DWG No.	C4497-C01-C	REF. No.	26-010-5001-0	



## Declaration of Conformity



We **FURUNO ELECTRIC CO., LTD.**

(Manufacturer)

9-52 Ashihara-Cho, Nishinomiya City, 662-8580, Hyogo, Japan

(Address)

declare under our sole responsibility that the product

**MONITOR UNIT MU-152**

(Model name, type number)

to which this declaration relates conforms to the following standard(s) or other normative document(s)

**EU**  
EMC Directive 2014/30/EU

**UK**  
SI 2016 No.1091 EMC Regulations 2016 as amended

IEC 60945 Ed.4.0: 2002

EN 60945: 2002

For assessment, see

- Test report  
Labotech International Co., Ltd.  
LIC 12-17-070, 31 Aug 2017

For assessment, see

- Test report  
Labotech International Co., Ltd.  
LIC 12-17-070, 31 Aug 2017

(title and/or number and date of issue of the standard(s) or other normative document(s))

On behalf of Furuno Electric Co., Ltd.

Nishinomiya City, Japan  
26 July 2021

(Place and date of issue)

Akihiko Kanechika  
Department General Manager  
Quality Assurance Department

(name and signature or equivalent marking of authorized person)



## PSTI Statement of Compliance

We **FURUNO ELECTRIC CO., LTD.**

(Name of manufacturer of the product)

**9-52 Ashihara-Cho, Nishinomiya City, 662-8580, Hyogo, Japan**

(Address of manufacturer of the product)

declare under our sole responsibility that the product

**MONITOR UNIT,  
MU-152**

(Product type, batch)

**April / 30 / 2028**

(Support period for the product)

**[https://www.furuno.co.jp/en/csr/sociality/customer/product\\_security.html](https://www.furuno.co.jp/en/csr/sociality/customer/product_security.html)**

(Weblink for latest information and contact to report to the manufacturer security issues)

to which this declaration relates conforms to the following standard(s) or other normative document(s)

Product Security and Telecommunications Infrastructure Act 2022

Product Security and Telecommunications Infrastructure (Security Requirements for  
Relevant Connectable Products) Regulations 2023 Schedule 1

On behalf of Furuno Electric Co., Ltd.

Nishinomiya City, Japan  
24 April 2024

(Place and date of issue)

Akihiko Kanechika  
Department General Manager  
Quality Assurance Department

(Signature, name and function of the signatory)

This page is intentionally left blank.



**FURUNO ELECTRIC CO., LTD.**

9-52 Ashihara-cho,  
Nishinomiya, 662-8580, JAPAN

• FURUNO Authorized Distributor/Dealer

All rights reserved. Printed in Japan

Pub. No. OME-44970-E1

(AIHA ) MU-152

A : FEB. 2018  
E1 : OCT. 27, 2025



0 0 0 1 9 4 2 9 3 1 4