

Installation Manual NETWORK FISH FINDER Model DFF3-UHD

A Word to the Owner of the DFF3-UHD

Congratulations on your choice of the FURUNO DFF3-UHD Network Fish Finder. The DFF3-UHD is a network fish finder designed for use with the NavNet TZtouch3 (TZT9F/12F/16F/19F, Ver. 3.01 or higher) and NavNet TZtouch2 (TZT2BB only, Ver.9.01 or higher). Please carefully read and follow the recommended procedures for installation and maintenance. Thank you for considering and purchasing FURUNO.

Operational Cautions

- A separate power supply is required. Take the power from the ship's mains via the ship's switchboard.
- The DFF3-UHD is not turned off when the multi function display is powered off. The DFF3-UHD's standby power is 6.2 W, so turn it off from the ship's switchboard when it is not in use.
- DFF3-UHD does not support the Bottom Discrimination, RezBoost, or ACCU-FISH.
- Do not transmit with the transducer out of water, to prevent damage to the transducer.
- Use the multi function display to change the program version of the power amp. Contact FURUNO for information on how to upgrade program version.
- When using two types of transducers, set them from [Fishfinder]-[Transducer Setup]-[Transducer Setup]-[Type] of the NavNet TZtouch3 and NavNet TZtouch2. Because the equipment has only one TDID port, two TDIDs cannot be read.
- The following concern acts as our importer in Europe, as defined in DECISION No 768/2008/EC.
 - Name: FURUNO EUROPE B.V.
 - Address: Ridderhaven 19B, 2984 BT Ridderkerk, The Netherlands
- The following concern acts as our importer in UK, as defined in SI 2016/1025 as amended SI 2019/470.
 - Name: FURUNO (UK) LTD.
 - Address: West Building Penner Road Havant Hampshire PO9 1QY, U.K.

Safety Instructions

The installer must read the safety instructions before attempting to install the equipment.

WARNING	Indicates a potentially hazardous situation which, if not avoided, could result in death or serious injury.
CAUTION	Indicates a potentially hazardous situation which, if not avoided, could result in minor or moderate injury.

Warning, Caution	Prohibitive Action	Mandatory Action
------------------	--------------------	------------------

<div style="text-align: center; background-color: black; color: white; padding: 2px;"> WARNING</div> <div style="padding: 5px;"> Do not disassemble or modify the equipment. Fire, electrical shock or serious injury can result. </div> <hr/> <div style="padding: 5px;"> Use the proper fuse. Use of a wrong fuse can damage the equipment and may cause fire. </div> <table border="1" style="margin-left: auto; margin-right: auto; text-align: center; border-collapse: collapse;"> <tr> <td style="padding: 2px;">12VDC</td> <td style="padding: 2px;">24VDC</td> </tr> <tr> <td style="padding: 2px;">7.5 A</td> <td style="padding: 2px;">7.5 A</td> </tr> </table>	12VDC	24VDC	7.5 A	7.5 A	<div style="text-align: center; background-color: black; color: white; padding: 2px;"> CAUTION</div> <div style="padding: 5px;"> Observe the following compass safe distance to prevent interference to a magnetic compass: </div> <table border="1" style="margin-left: auto; margin-right: auto; text-align: center; border-collapse: collapse;"> <tr> <td style="padding: 2px;">Standard compass</td> <td style="padding: 2px;">Steering compass</td> </tr> <tr> <td style="padding: 2px;">0.35 m</td> <td style="padding: 2px;">0.3 m</td> </tr> </table>	Standard compass	Steering compass	0.35 m	0.3 m
12VDC	24VDC								
7.5 A	7.5 A								
Standard compass	Steering compass								
0.35 m	0.3 m								

和文の装備要領書 (IMJ-20410-*) を当社 HP で公開しています。左記の二次元コードからアクセスしてください。



FURUNO ELECTRIC CO., LTD.

www.furuno.com

Equipment List

Name	Type	Qty	Remark
Network Fish Finder	DFF3-UHD	1	
Installation Materials	CP02-09900	1	- FRU-3P-FF-A002M-001 (Cable assembly) - MOD-Z071-050+ (LAN cable) - CP02-09901 (EMI core and Self-tapping screw)

Option

Name	Type	Qty	Remark
Extension Cable	C44-02 30M	1	For tank w/transducer (CM265LH, CM265LM, CM599LH, CM599LM, PM111LH, PM111LM, CM275LH-W)
	C44-02 50M	1	
	C334 30M	1	For thru-hull transducer.
LAN Cable	MOD-Z072-020+	1	2 m
	MOD-Z072-100+	1	10 m
Transducer	PM111LHG	1	2 kW 38-75/130-210 kHz
	CM599LHG	1	2 kW 28-60/130-210 kHz
Thru-Hull Pipe	TFB-7000(1)	1	
AC/DC Power Supply Unit	PR-241	1	
Ferrite Core	OP86-11	1	For PR-241

CE/UKCA Declaration

With regards to CE/UKCA declarations, please refer to our website (www.furuno.com) for further information about RoHS conformity declarations.

Disclosure of Information about China RoHS

With regards to China RoHS information for our products, please refer to our website (www.furuno.com).

Installation

Select the mounting location considering the following points.

- Locate the unit away from areas subject to water splash.
- Select a location that is well ventilated.
- Observe the compass safe distances shown on page 1.
- Leave the sufficient service clearance around the unit.

Procedure

1. Drill four pilot holes in the bulkhead (or tabletop) for the self-tapping screws.
2. Screw two self-tapping screws ($\phi 5 \times 20$) into the pilot holes for upper, leave 5 mm protruding.
3. Set unit onto the screws and fasten them.

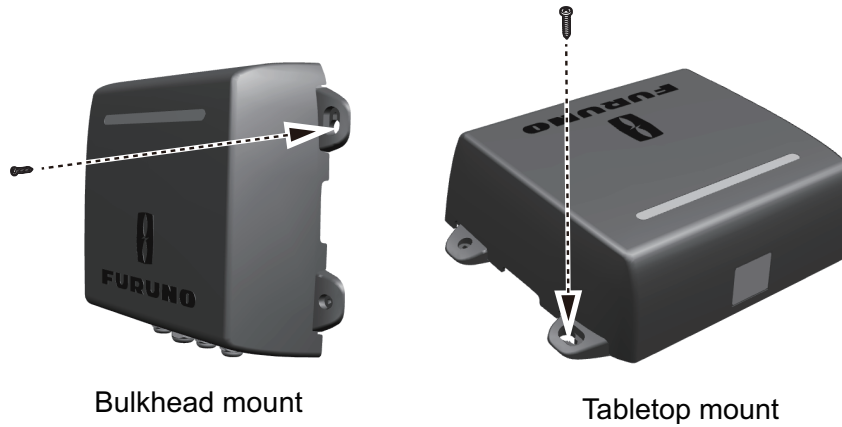

4. Tightly fasten the other two screws to fix the unit in place.

Note: For mounting on a bulkhead, the connectors must face downward.

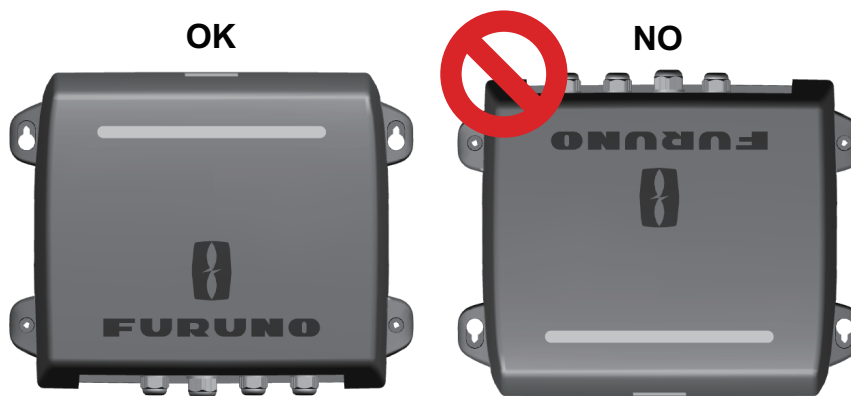

Wiring

Wiring Outline

The figure below shows the inserting position of each cables for the DFF3-UHD. Refer to the interconnection diagram for details.

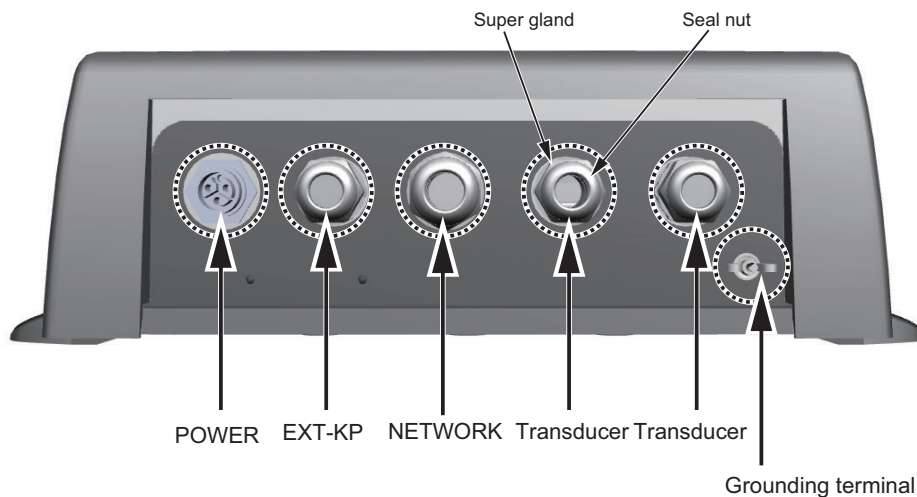

Inserting position of cables

Procedure

1. Remove the cover.
2. Unfasten four screws to remove the chassis cover.

[Transducer cable wiring]

3. Fabricate the transducer cable(s) as shown below.
Fabricate the cables for both the high and low frequencies. For a CHIRP transducer, fabricate the ID signal cores for both the high and low frequencies.

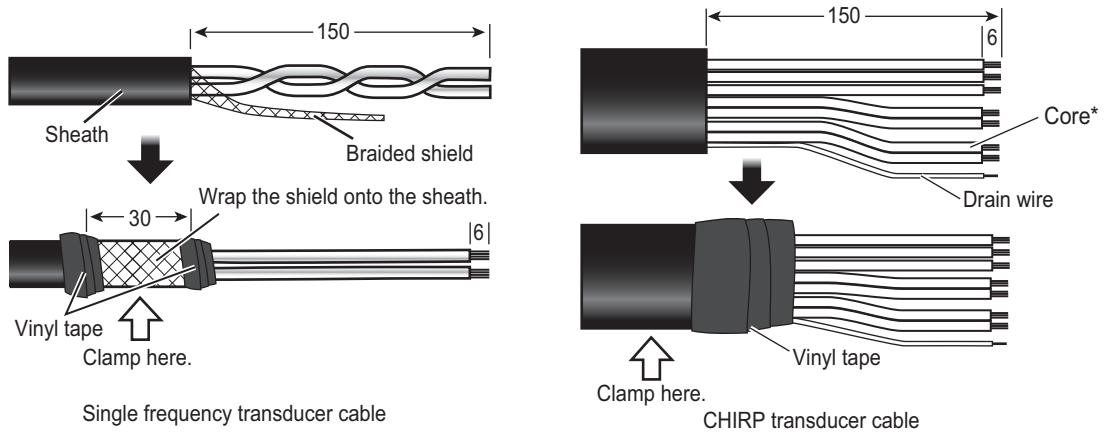

Note: When the previous CHIRP transducer cable (with 4 drain wires and braided shield) is used, turn back the shield onto the sheath and fix with vinyl tape.

4. Unfasten the seal nut on the cable entry for transducer cable.
5. Pass the seal nut, claw and seal onto the transducer cable, in that order.

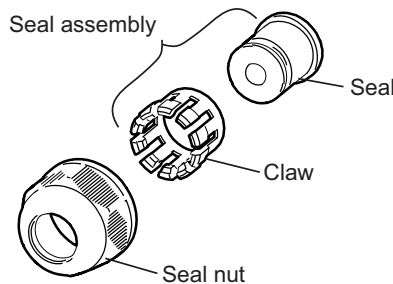

6. Push the seal assembly into the seal nut, then tighten the super gland.
7. Remove the WAGO connectors from the PCB, then attach the transducer cable to the connector.

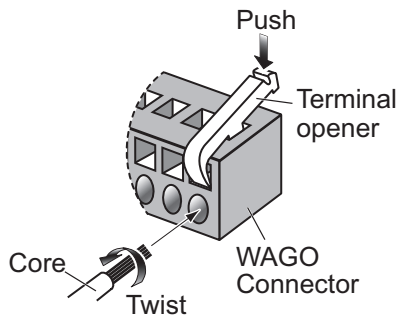

Procedure

1. Twist conductors.
2. Insert terminal opener and push.
3. Insert a conductor into hole.
4. Release the terminal opener.
5. Pull the core to confirm it is correctly inserted.

8. Clamp the braided shield with a cable clamp.

9. Attach the WAGO connector to the PCB.

For two sets of single frequency transducers

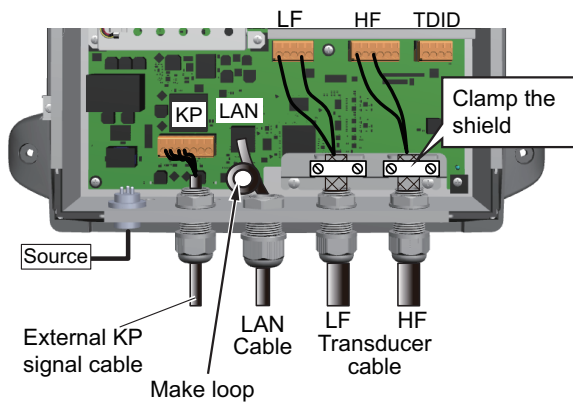

For CHIRP transducer

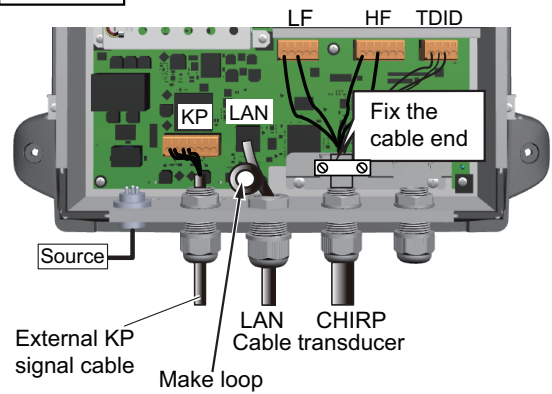

Note: For previous CHIRP transducer cable, connect the drain wires to the connector and clamp the shield.

[LAN cable and external KP signal cable wiring]

10. Connect the LAN cable to the LAN connector. As shown in the above figure, make a loop in the cable (approx. 10mm diameter), then connect the cable.
11. Fasten the seal nut to fix the transducer cable. The torque shall be 2.0 Nm and the gap between the seal nut and the super gland shall be approx. 3 mm.
12. Fabricate the external KP signal cable as shown below. (core size 0.75 sq, outer dia 7.6 approx.)

External KP signal cable (local supply)
VCTF0.75x4C

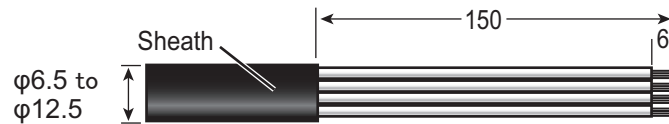

13. Pass the cable through the seal nut and seal assembly, like you did with the transducer cable.
14. Push the seal assembly into the seal nut, then tighten the super gland.
15. Remove the WAGO connector from the PCB and connect it to the external KP signal cable.
16. Connect WAGO connector to the PCB.
17. Tighten the seal nut to fasten the cable.
18. Attach the EMI core (GRFC-8, supplied) to the power cable near the super gland to prevent noise (see figure below).

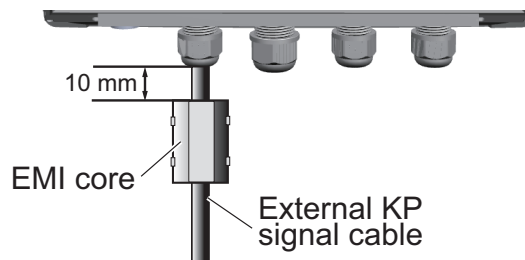

19. Attach the ground wire (IV-1.25sq, local supply) to the ground terminal with a crimp-on lug (M3, local supply) to prevent interference.
20. Reattach the chassis cover.
21. Reattach the cover.

For networking two units

A maximum of two DFF3-UHD units can be connected on the same network. When two units are installed, change the DIP switch setting on one unit to assign a unique IP address on that unit. Turn ON the #2 switch of DIP switch S1 as shown in the figure below.

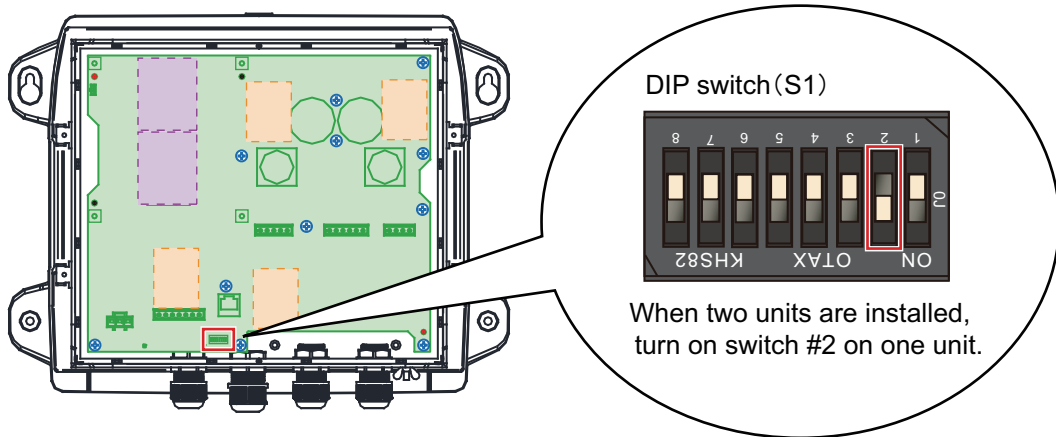

Operation Check

For NavNet TZtouch3 and NavNet TZtouch2, the DFF3-UHD is powered on/off from the ship's switchboard. The STATUS LED and ERROR LED on the bottom of the DFF3-UHD lights or blinks according to equipment state, as described in the table below.

LED Type	STATUS	ERROR	Meaning
LED State	Blinking every two seconds	Off	Normal operation
	Blinking every 0.4 seconds	Off	Transducer settings at NavNet device not properly set.
	Off	Lit continuously	Communication error with NavNet device or internal fan error (see "Troubleshooting" about how to solve the problem).



LED Position

Troubleshooting

The table below provides basic troubleshooting procedures which the user may follow to restore normal operation. If you cannot restore normal operation, do not check inside unit. Have a FURUNO dealer check the equipment.

Problem	Reason
Cannot turn on power.	<ul style="list-style-type: none">• The power cable is disconnected or damaged. Check the power cable and if it damaged, replace it.• Check the ship's mains and check if the switchboard is turned on.• Check the fuse on the power cable. If the fuse has blown, find the cause then replace it.
No echo appears but fixed range scale appears.	<ul style="list-style-type: none">• The sensor cable is disconnected or damaged. Check the cable and reconnect or replace it as necessary.
Sensitivity is low.	<ul style="list-style-type: none">• Gain setting is too low. Raise the gain.• Marine life is adhering to the transducer face. Clean the transducer face.• Vessel is in heavily sedimented water.
ERROR LED turns on.	<ul style="list-style-type: none">• Disconnect the Power cable and LAN cable.• Connect the Power cable and LAN cable.• Contact your local dealer for advice when the problem cannot be solved.

Specifications

Frequency	25 to 242 kHz
Number of channels	2 ch
Output power	3 kW
Power supply	12-24 VDC: 3.0-1.6 A
Environmental conditions	
Ambient temperature	-15°C to +55°C
Degree of protection	IP55
Vibration	IEC60945 Ed.4
External KP Input	5-12 VDC, Positive
External KP Output	12 VDC, Positive

Transducer List

The below shows the transducers that can be connected.

Note: CHIRP transducers (dual frequency) are the products of AIRMAR Technology Corporation.

CHIRP transducers (dual frequency)

R109LM	PM411LWM	165T-PM542LM
R109LH	CM599LM	165T-PM542LHW
R109LHW	CM599LH/	
R111LM	CM599LHG	
R111LH	CM599LHW	
R409LWM	R509LM	
PM111LM	R509LH	
PM111LH	R509LHW	
PM111LHG	R599LM	
PM111LHW	R599LH	

Standard transducers (CW narrow band)

28BL-6HR	68F-30H
28BL-12HR	82B-35R
28F-38M	88B-10
28F-72	88F-126H
38BL-9HR	100B-10R
38BL-15HR	150B-12H
50BL-12HR	200B-8
50BL-24HR	200B-8B
50F-38	200B-12H
50F-70	

Licensed Software

This product includes software licensed under BSD-3-Clause and others. Please refer to the following for details on the terms of the software.

Intel-socfpga-hwlib

Copyright 2013-2020 Intel Corporation. All Rights Reserved.

Redistribution and use in source and binary forms, with or without modification, are permitted provided that the following conditions are met:

1. Redistributions of source code must retain the above copyright notice, this list of conditions and the following disclaimer.
2. Redistributions in binary form must reproduce the above copyright notice, this list of conditions and the following disclaimer in the documentation and/or other materials provided with the distribution.
3. Neither the name of the copyright holder nor the names of its contributors may be used to endorse or promote products derived from this software without specific prior written permission.

THIS SOFTWARE IS PROVIDED BY THE COPYRIGHT HOLDERS AND CONTRIBUTORS "AS IS" AND ANY EXPRESS OR IMPLIED WARRANTIES, INCLUDING, BUT NOT LIMITED TO, THE IMPLIED WARRANTIES OF MERCHANTABILITY AND FITNESS FOR A PARTICULAR PURPOSE ARE DISCLAIMED. IN NO EVENT SHALL THE COPYRIGHT HOLDER OR CONTRIBUTORS BE LIABLE FOR ANY DIRECT, INDIRECT, INCIDENTAL, SPECIAL, EXEMPLARY, OR CONSEQUENTIAL DAMAGES (INCLUDING, BUT NOT LIMITED TO, PROCUREMENT OF SUBSTITUTE GOODS OR SERVICES; LOSS OF USE, DATA, OR PROFITS; OR BUSINESS INTERRUPTION) HOWEVER CAUSED AND ON ANY THEORY OF LIABILITY, WHETHER IN CONTRACT, STRICT LIABILITY, OR TORT (INCLUDING NEGLIGENCE OR OTHERWISE) ARISING IN ANY WAY OUT OF THE USE OF THIS SOFTWARE, EVEN IF ADVISED OF THE POSSIBILITY OF SUCH DAMAGE.

Altera-SoCFPGA-HardwareLib-MPL

Altera MPL preloader, configured for use with SDMMC/Connectal. (The initial commit is the unmodified sourcecode from Altera)

The original source was extracted from: altera/14.1/embedded/examples/software/Altera-SoCFPGA-HardwareLib-MPL.tar.gz and has BSD copyright with the additional restriction: "This software may only be used to run on Altera products, or to program Altera devices."

All subsequent edits by Cambridgehackers are under the same copyright.

P A C K I N G L I S T

DFF3-UHD

02HA-X-9851 -2 1/1

A-1

N A M E	O U T L I N E	DESCRIPTION/CODE No.	Q' TY
ユニット UNIT			
ネットワーク魚探 NETWORK FISH FINDER		DFF3-UHD	1
		000-038-529-00	
工事材料 INSTALLATION MATERIALS			
ケーブル(組品) CABLE ASSEMBLY		FRU-3P-FF-A002M-001	1
		000-100-303-20	
ケーブル(組品)LAN LAN CABLE ASSEMBLY		MOD-Z072-050+	1
		001-167-890-10	
工事材料袋詰 INSTALLATION MATERIALS		CP02-09901	1
		001-621-550-00	
図書 DOCUMENT			
装備要領書(英) INSTALLATION MANUAL (EN)		IME-20410-*	1
		000-199-256-1*	

表 1 TABLE 1

寸法範囲 (mm) DIMENSION	公差 (mm) TOLERANCE
$L \leq 50$	± 1.5
$50 < L \leq 100$	± 2.5
$100 < L \leq 500$	± 3

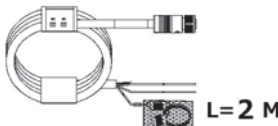
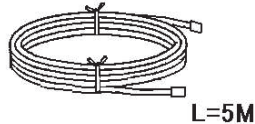
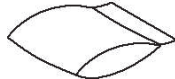
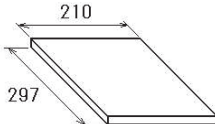
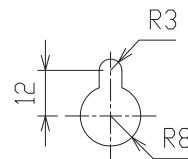
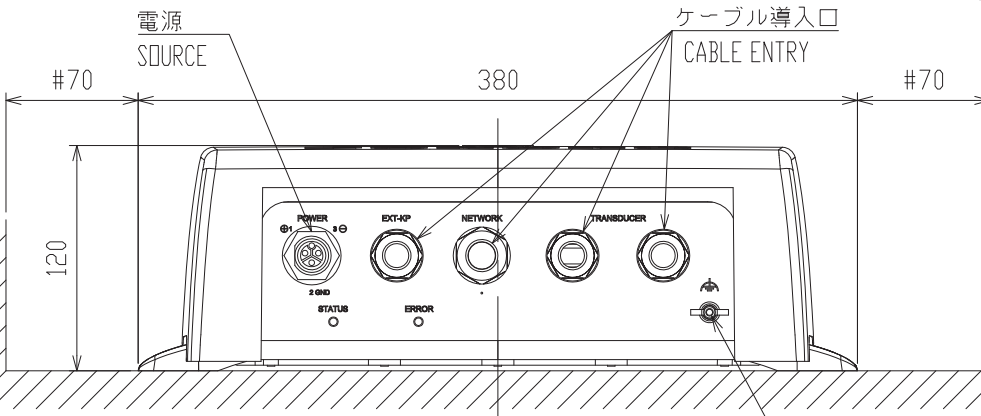
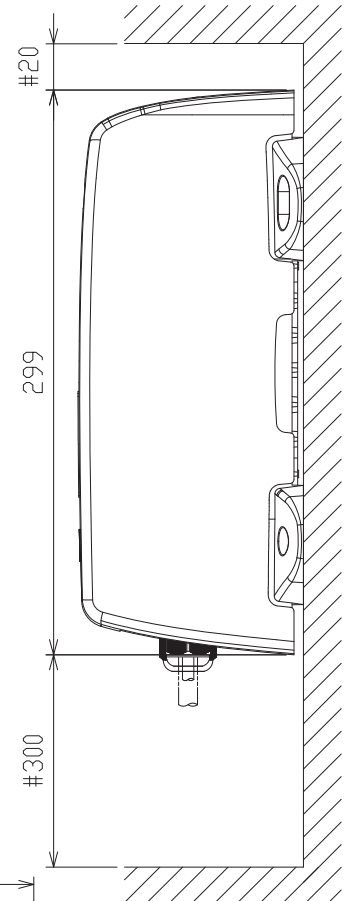
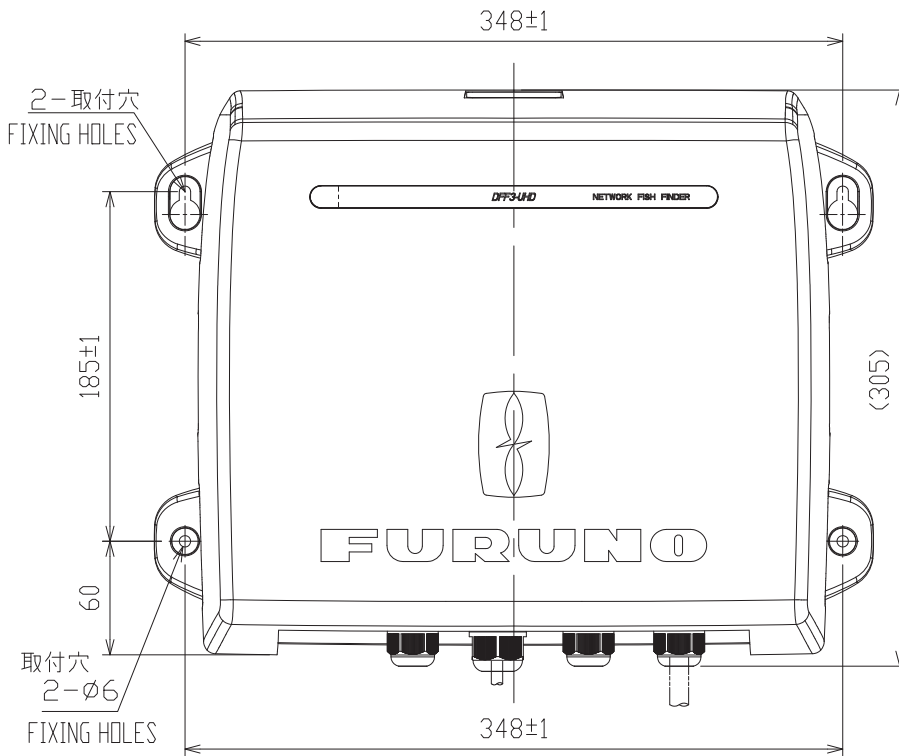
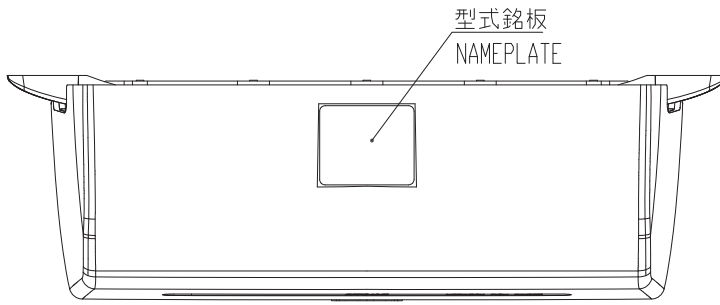

取付穴詳細 (尺度: 1/2)
DETAIL FOR FIXING HOLE

- 注記 1) 指定なき寸法公差は表1による。
2) 取付用ネジはトラスタッピングネジ呼び径5X20を使用のこと。
3) 壁掛時、ケーブルは下方のみとする。

- NOTE 1. TABLE 1 INDICATES TOLERANCE OF DIMENSIONS WHICH IS NOT SPECIFIED.
2. USE TAPPING SCREWS φ5x20 FOR FIXING THE UNIT.
3. FACE THE CABLES DOWNWARD FOR BULKHEAD MOUNT.

DRAWN 7/Jan/2022 T.YAMASAKI		TITLE DF3-UHD
CHECKED 7/Jan/2021 H.MAKI		名称 ネットワーク魚探 (卓上・壁掛装備)
APPROVED 3/Feb/2022 H.MAKI		外寸図
SCALE 1/4	MASS 3.6 ±10% kg	NAME NETWORK FISH FINDER (TABLETOP/BULKHEAD MOUNT)
DWG. No. C2041-G01-A	REF. No. 02-180-500G-1	質量はケーブルを含まず。 MASS DOES NOT INCLUDE CABLE.
		OUTLINE DRAWING

4

3

2

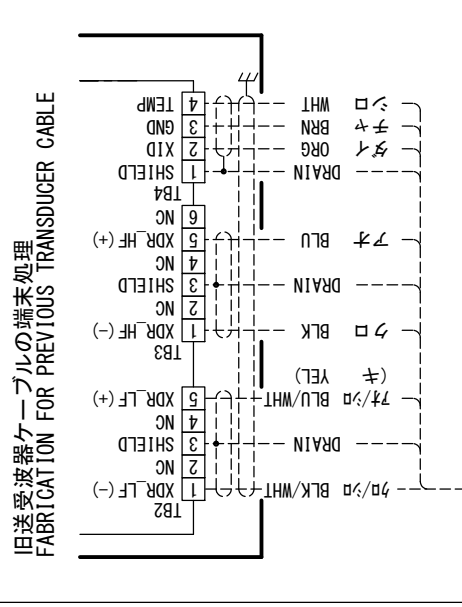
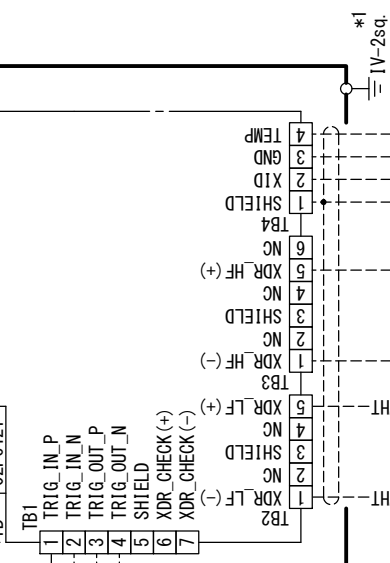
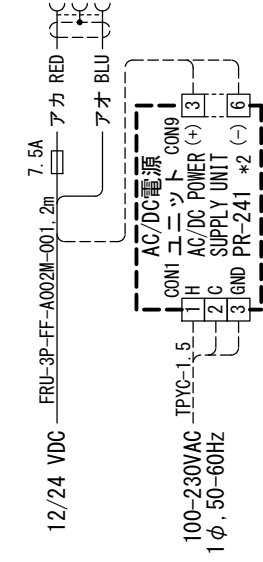
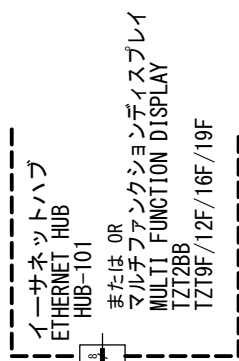



Declaration of Conformity



We **FURUNO ELECTRIC CO., LTD.**

(Manufacturer)

9-52 Ashihara-Cho, Nishinomiya City, 662-8580, Hyogo, Japan

(Address)

declare under our sole responsibility that the product

NETWORK FISH FINDER DFF3-UHD

(Model name, type number)

to which this declaration relates conforms to the following standard(s) or other normative document(s)

EU

EMC Directive 2014/30/EU

IEC 60945 Ed.4.0: 2002

For assessment, see

- Test report
Labotech International Co., Ltd.
LIC 12-22-008, 8 Feb 2022
LIC 12-22-010, 8 Feb 2022

UK

SI 2016 No.1091 EMC Regulations 2016 as amended

EN 60945: 2002

For assessment, see

- Test report
Labotech International Co., Ltd.
LIC 12-22-008, 8 Feb 2022
LIC 12-22-010, 8 Feb 2022

(title and/or number and date of issue of the standard(s) or other normative document(s))

On behalf of Furuno Electric Co., Ltd.

Nishinomiya City, Japan
8 February 2022

(Place and date of issue)

Akihiko Kanechika
Department General Manager
Quality Assurance Department

(name and signature or equivalent marking of authorized person)



PSTI Statement of Compliance

We **FURUNO ELECTRIC CO., LTD.**

(Name of manufacturer of the product)

9-52 Ashihara-Cho, Nishinomiya City, 662-8580, Hyogo, Japan

(Address of manufacturer of the product)

declare under our sole responsibility that the product

**NETWORK FISH FINDER,
DFF3-UHD**

(Product type, batch)

December / 31 / 2028

(Support period for the product)

https://www.furuno.co.jp/en/csr/sociality/customer/product_security.html

(Weblink for latest information and contact to report to the manufacturer security issues)

to which this declaration relates conforms to the following standard(s) or other normative document(s)

Product Security and Telecommunications Infrastructure Act 2022

Product Security and Telecommunications Infrastructure (Security Requirements for
Relevant Connectable Products) Regulations 2023 Schedule 1

On behalf of Furuno Electric Co., Ltd.

Nishinomiya City, Japan
24 April 2024

(Place and date of issue)

Akihiko Kanechika
Department General Manager
Quality Assurance Department

(Signature, name and function of the signatory)

This page is intentionally left blank.

FURUNO ELECTRIC CO., LTD.

9-52 Ashihara-cho,
Nishinomiya, 662-8580, JAPAN

• FURUNO Authorized Distributor/Dealer

All rights reserved. Printed in Japan

Pub. No. IME-20410-E1

(TEHI) DFF3-UHD

A : FEB. 2022
E1 : JAN. 22, 2026



0 0 0 1 0 0 0 5 2 2 0